

**Meiko USA**  
 1349 Heil Quaker Blvd.  
 Lavergne, TN 37086  
 800-868-3840

**WIRING DIAGRAM**

Model Number : FV250.2 / DV270.2  
 Voltage : 208V-240VAC 60Hz  
 Phase : 3 Phase

Released For Production :

Editor : SZ

**FOR USE WITH THE FOLLOWING OPTIONS:**

- Internal Chemical Dosing Pumps
- Drain Water Tempering Kit
- Power Cord Kit
- External Vent Fan Control
- Dual Tank Fill System

RELEASE FOR PRODUCTION	04/01/2005	LST	
RELEASE ON SUPPLY	04/01/2005	LST	
LAST DRAWER	11/10/2009	SZ	
REVISION			

WIRING DIAGRAM



FV250.2 / DV270.2 USA  
 208V - 240V 3 PH+G 60Hz  
 COVER PAGE

9622296

FV250.2 / DV270.2

INPUT / OUTPUT ALLOCATION TABLE			
LEVEL	INPUT / OUTPUT	ASSIGNMENT	CONNECTION
2-2	INPUT 1	S1: DOOR CLOSED	XA6 1/9
2-2	INPUT 2	S2: BOOSTER LEVEL SWITCH	XA6 2/10
2-2	INPUT 3	S3: FLOOR LEAKAGE	XA6 3
2-2	INPUT 4		XA6 4/12
2-2	INPUT 5		XA6 5/13
2-2	INPUT 6		XA6 6/14
2-2	INPUT 7		XA6 7/15
2-2	INPUT 8		XA6 8/16
2-2	INPUT 9	FSK: RINSE AID LEVEL (OPT.)	XA4 1/2
2-2	INPUT 10	FSR: DETERGENT LEVEL (OPT.)	XA4 3/4
2-2	INPUT 11	LD: CHEMICAL LEAK DETECTION	XA4 5/6
2-2	INPUT 12		XA4 7/8
2-2	INPUT 22		XA4 9/10
2-2	INPUT 19	B1: BOOSTER TEMPERATURE	XA5 1/2
2-2	INPUT 20	B2: TANK TEMPERATURE	XA5 3/4
2-2	INPUT 21	B3: TANK LEVEL	XA10 1/2/3
2-3	OUTPUT 1	K5: BOOSTER PUMP CONTACTOR	XA1 4
2-3	OUTPUT 2	M6: GEARED MOTOR (WASH ARM MOTION)	XA1 5
2-3	OUTPUT 3	M5: DRAIN PUMP	XA1 6
2-3	OUTPUT 4	M3/KP: RINSE AID DOSING	XA2 2
2-3	OUTPUT 5	M4/RP: DETERGENT DOSING	XA2 7
2-3	OUTPUT 6	K4: POWER CUTTING CONTACTOR	XA2 9
2-3	OUTPUT 7	Y1: FILLING VALVE	XA3 1
2-3	OUTPUT 8	Y2.1/Y2.2: SOFT START VALVE	XA3 2
2-3	OUTPUT 9	K1.1/K1.2: BOOSTER HEATING CONTACTOR	XA3 3
2-3	OUTPUT 10	K2.1/K2.2: TANK HEATING CONTACTOR	XA3 4
2-3	OUTPUT 11	K3.1/K3.2: WASH PUMP CONTACTOR	XA3 5
2-3	OUTPUT 12		XA3 6

RELEASE FOR PRODUCTION	04/01/2005	LST	
RELEASE ON SUPPLY	04/01/2005	LST	
LAST DRAWER	11/10/2009	SZ	
REVISION			

WIRING DIAGRAM



FV250.2 / DV270.2 USA  
 208V - 240V 3 PH+G 60Hz  
 ALLOCATION TABLE

9622296  
 FV250.2 / DV270.2

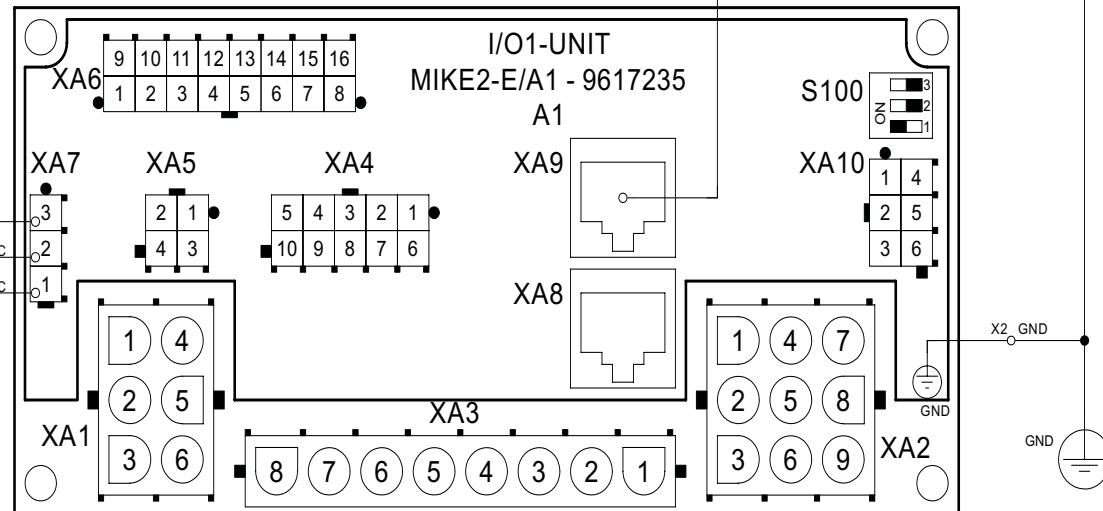
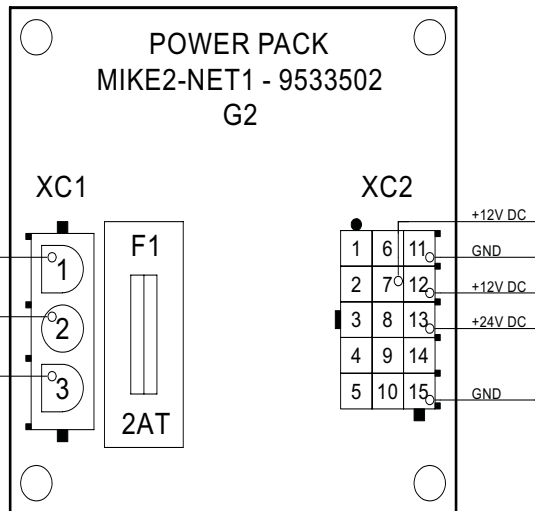
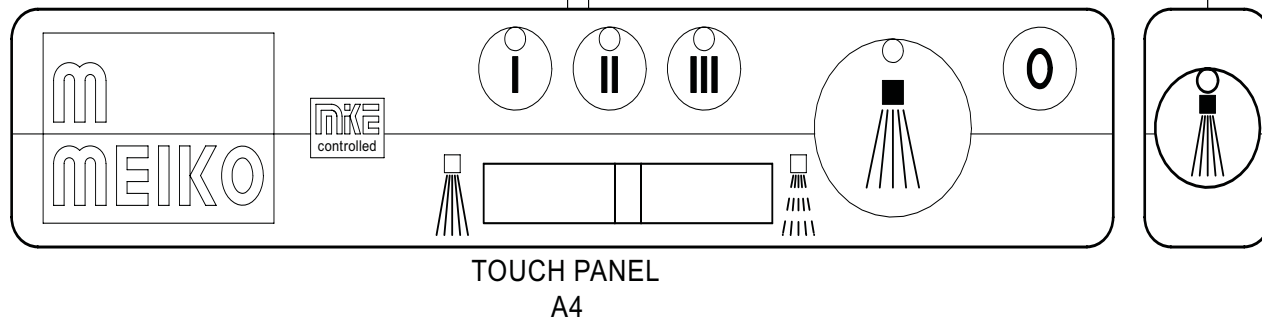
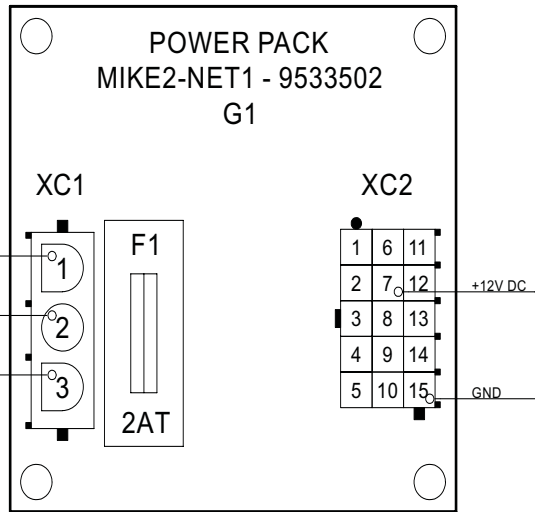
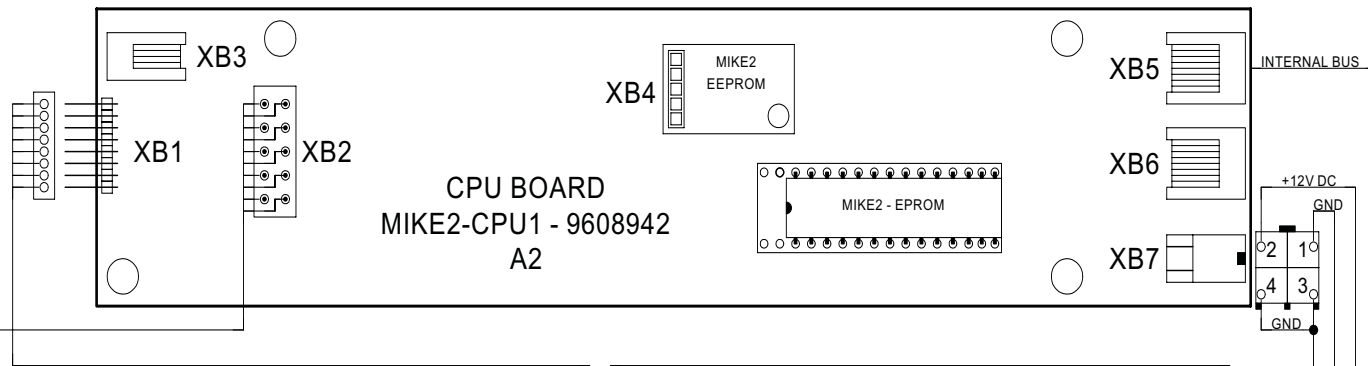
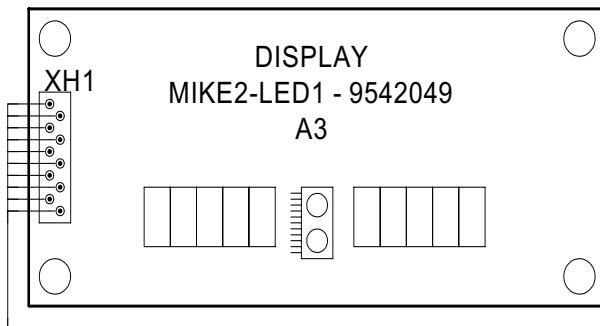

RELEASE FOR PRODUCTION	04/01/2005	LST	
RELEASE ON SUPPLY	04/01/2005	LST	
LAST DRAWER	11/10/2009	SZ	
REVISION			

WIRING DIAGRAM



FV250.2 / DV270.2 USA  
208V - 240V 3 PH+G 60Hz  
ELECTRONIC CONTROL

9622296

FV250.2 / DV270.2

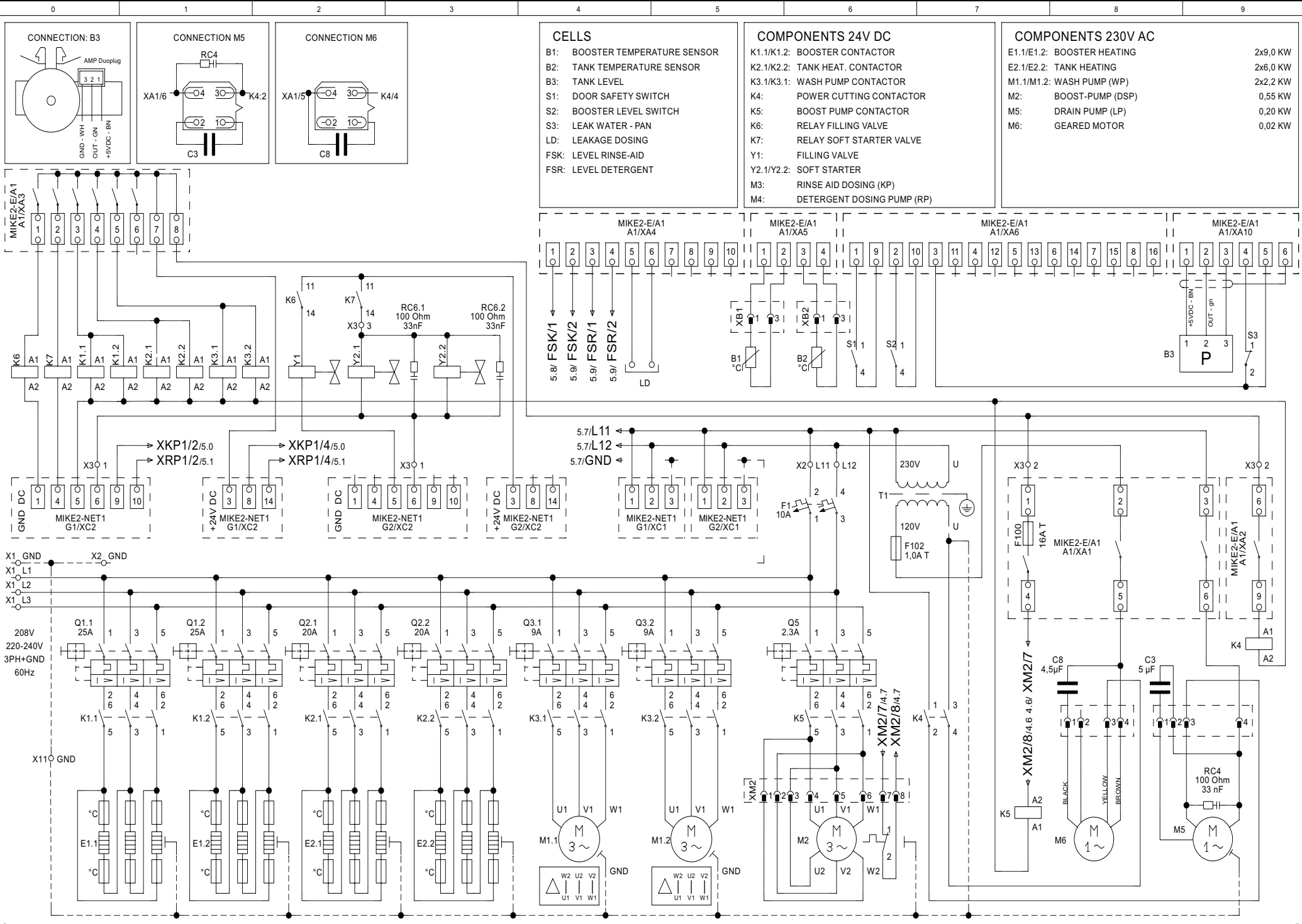

- ### CELLS
- B1: BOOSTER TEMPERATURE SENSOR
  - B2: TANK TEMPERATURE SENSOR
  - B3: TANK LEVEL
  - S1: DOOR SAFETY SWITCH
  - S2: BOOSTER LEVEL SWITCH
  - S3: LEAK WATER - PAN
  - LD: LEAKAGE DOSING
  - FSK: LEVEL RINSE-AID
  - FSR: LEVEL DETERGENT

- ### COMPONENTS 24V DC
- K1.1/K1.2: BOOSTER CONTACTOR
  - K2.1/K2.2: TANK HEAT. CONTACTOR
  - K3.1/K3.1: WASH PUMP CONTACTOR
  - K4: POWER CUTTING CONTACTOR
  - K5: BOOST PUMP CONTACTOR
  - K6: RELAY FILLING VALVE
  - K7: RELAY SOFT STARTER VALVE
  - Y1: FILLING VALVE
  - Y2.1/Y2.2: SOFT STARTER
  - M3: RINSE AID DOSING (KP)
  - M4: DETERGENT DOSING PUMP (RP)

- ### COMPONENTS 230V AC
- E1.1/E1.2: BOOSTER HEATING 2x9,0 KW
  - E2.1/E2.2: TANK HEATING 2x6,0 KW
  - M1.1/M1.2: WASH PUMP (WP) 2x2,2 KW
  - M2: BOOST-PUMP (DSP) 0,55 KW
  - M5: DRAIN PUMP (LP) 0,20 KW
  - M6: GEARED MOTOR 0,02 KW

RELEASE FOR PRODUCTION	04/01/2005	LST
RELEASE ON SUPPLY	04/01/2005	LST
LAST DRAWER	11/10/2009	SZ
REVISION		

**WIRING DIAGRAM**

FV250.2 / DV270.2 USA  
 208V - 240V 3PH+G 60Hz  
 ELECTRONIC CONTROL

INTERNAL DOSING PUMPS - 24VDC

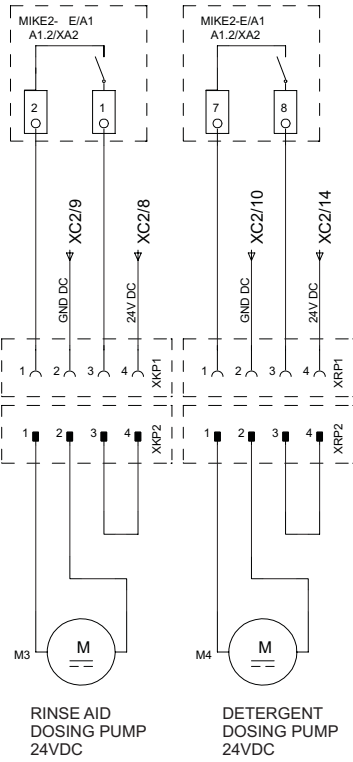

EXTERNAL DOSING PUMPS - LINE VOLTAGE

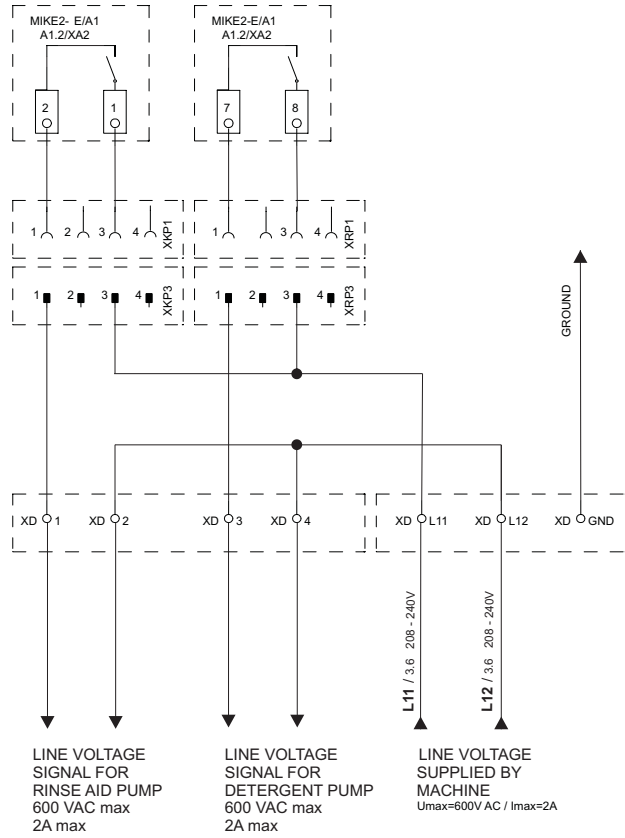

CHEMICAL AGENT LEVEL SENSOR (OPTIONAL)

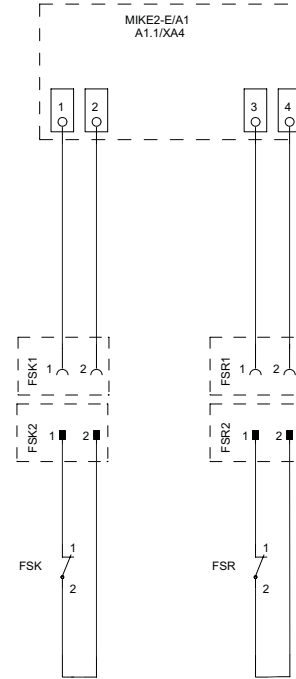

CHEMICAL AGENT LEVEL SENSOR (OPTIONAL)

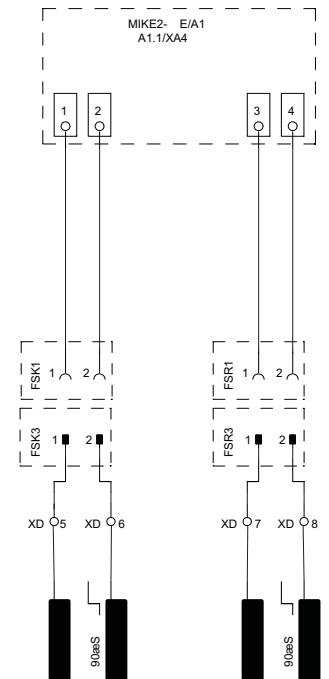

4

RELEASE FOR PRODUCTION	04/01/2005	LST
RELEASE ON SUPPLY	04/01/2005	LST
LAST DRAWER	11/10/2009	SZ
REVISION		

WIRING DIAGRAM



FV250.2 / DV270.2 USA  
208V - 240V 3 PH+G 60Hz  
CHEMICAL DOSING CONNECTIONS

9622296	
FV250.2 / DV270.2	Page 5

### EXTERNAL VENT FAN CONTROL

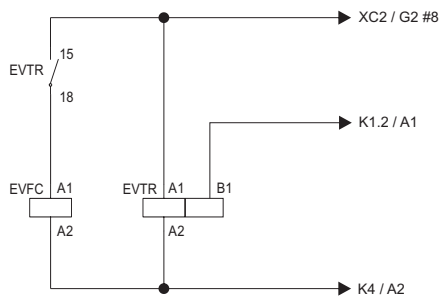

LINE VOLTAGE  
FOR EXHAUST  
FAN - IN\*

LINE VOLTAGE  
TO EXHAUST  
FAN - OUT\*

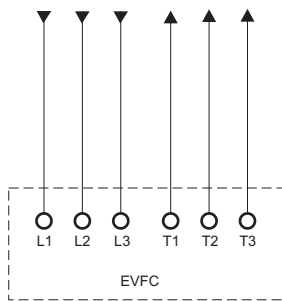

EVFC

\* 12 AWG 20A MAXIMUM

### EVTR TIMER SETTINGS - DIAL STYLE

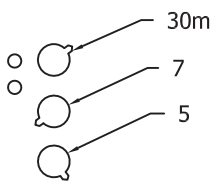

### EVTR TIMER SETTINGS - DIP SWITCH STYLE



SET TO 80 %

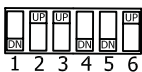

SET DIP SWITCHES TO:

- 1 - DOWN
- 2 - UP
- 3 - UP
- 4 - DOWN
- 5 - DOWN
- 6 - UP

### WASH TANK FILL

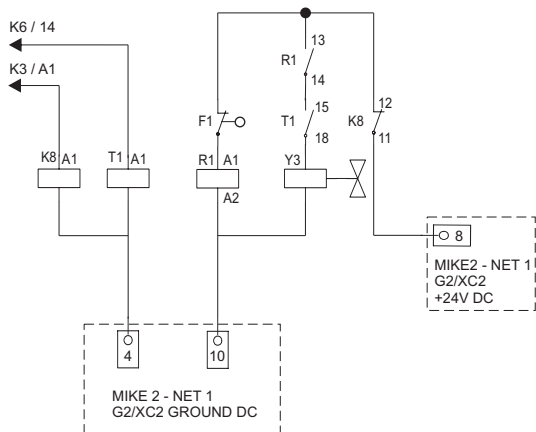

- F1: WASH TANK FLOAT
- K8: ANTI CHATTER RELAY
- R1: WASH TANK FILL RELAY
- T1: OFF DELAY TIMER WASH TANK FILL (SET TO 30 SECONDS)
- Y3: WASH TANK FILLING VALVE

5

RELEASE FOR PRODUCTION	04/01/2005	LST	
RELEASE ON SUPPLY	04/01/2005	LST	
LAST DRAWER	03/21/2005	LST	
REVISION			

WIRING DIAGRAM



FV250.2 / DV270.2 USA  
208V - 240V 3 PH+G 60Hz  
MACHINE OPTIONS

9622296

FV250.2 / DV270.2