

MEIKO USA
 1349 Heil Quaker Blvd.
 Lavergne, TN 37086
 800-868-3840

WIRING DIAGRAM

Model Number : FV130.2
 Voltage : 208V-240VAC 60Hz
 Phase : 3 Phase

Released For Production :

Editor : SZ

FOR USE WITH THE FOLLOWING OPTIONS:

- Internal Chemical Dosing Pumps
- Drain Water Tempering Kit
- Power Cord Kit
- External Vent Fan Control
- Dual Tank Fill System

RELEASE FOR PRODUCTION	04/01/2005	LST	
RELEASE ON SUPPLY	04/01/2005	LST	
LAST DRAWER	11/09/09	SZ	
REVISION			

WIRING DIAGRAM



FV130.2 USA
 208V - 240V 3 PH+G 60Hz
 COVER PAGE

9545585

FV130.2

INPUT / OUTPUT ALLOCATION TABLE			
LEVEL	INPUT / OUTPUT	ASSIGNMENT	CONNECTION
2-2	INPUT 1	S1: DOOR CLOSED	XA6 1/9
2-2	INPUT 2	S2: BOOSTER LEVEL SWITCH	XA6 2/10
2-2	INPUT 3	S3: FLOOR LEAKAGE	XA6 3
2-2	INPUT 4		XA6 4/12
2-2	INPUT 5		XA6 5/13
2-2	INPUT 6		XA6 6/14
2-2	INPUT 7		XA6 7/15
2-2	INPUT 8		XA6 8/16
2-2	INPUT 9	FSK: RINSE AID LEVEL (OPT.)	XA4 1/2
2-2	INPUT 10	FSR: DETERGENT LEVEL (OPT.)	XA4 3/4
2-2	INPUT 11	LD: CHEMICAL LEAK DETECTION	XA4 5/6
2-2	INPUT 12		XA4 7/8
2-2	INPUT 22		XA4 9/10
2-2	INPUT 19	B1: BOOSTER TEMPERATURE	XA5 1/2
2-2	INPUT 20	B2: TANK TEMPERATURE	XA5 3/4
2-2	INPUT 21	B3: TANK LEVEL	XA10 1/2/3
2-3	OUTPUT 1	K5: BOOSTER PUMP CONTACTOR	XA1 4
2-3	OUTPUT 2	M6: GEARED MOTOR (WASH ARM MOTION)	XA1 5
2-3	OUTPUT 3	M5: DRAIN PUMP	XA1 6
2-3	OUTPUT 4	M3/KP: RINSE AID DOSING	XA2 2
2-3	OUTPUT 5	M4/RP: DETERGENT DOSING	XA2 7
2-3	OUTPUT 6	K4: POWER CUTTING CONTACTOR	XA2 9
2-3	OUTPUT 7	Y1: FILLING VALVE	XA3 1
2-3	OUTPUT 8	Y2: SOFT START VALVE	XA3 2
2-3	OUTPUT 9	K1.1/1.2:BOOSTER HEATING CONTACTOR	XA3 3
2-3	OUTPUT 10	K2: TANK HEATING CONTACTOR	XA3 4
2-3	OUTPUT 11	K3: WASH PUMP CONTACTOR	XA3 5
2-3	OUTPUT 12		XA3 6

RELEASE FOR PRODUCTION	04/01/2005	LST	
RELEASE ON SUPPLY	04/01/2005	LST	
LAST DRAWER	03/21/2005	LST	
REVISION			

WIRING DIAGRAM



FV130.2 USA
208V - 240V 3 PH+G 60Hz
ALLOCATION TABLE

9545585
FV130.2

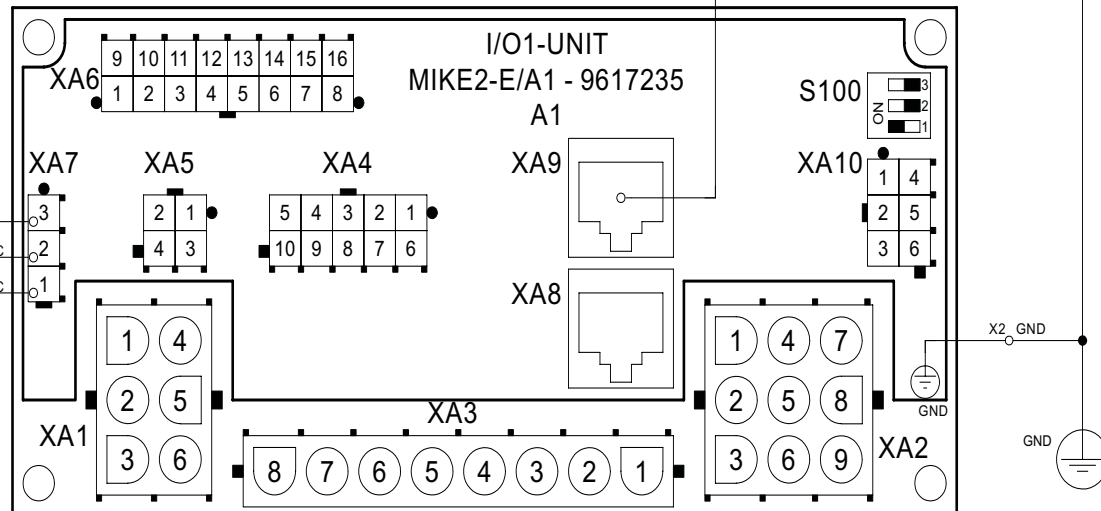
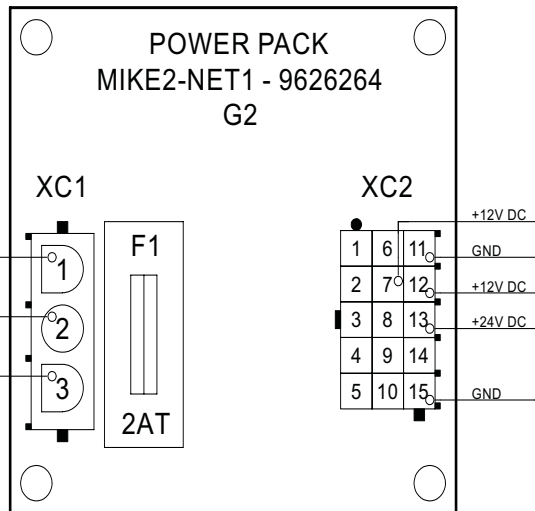
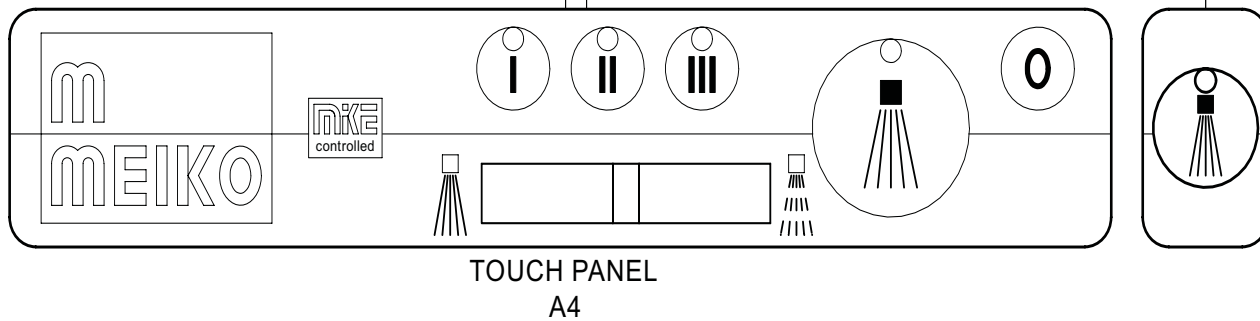
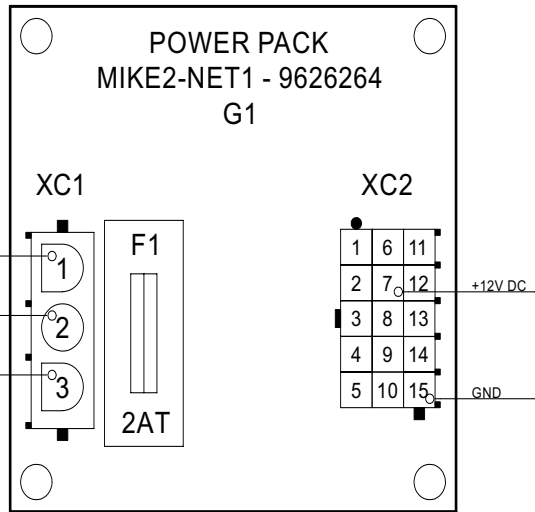
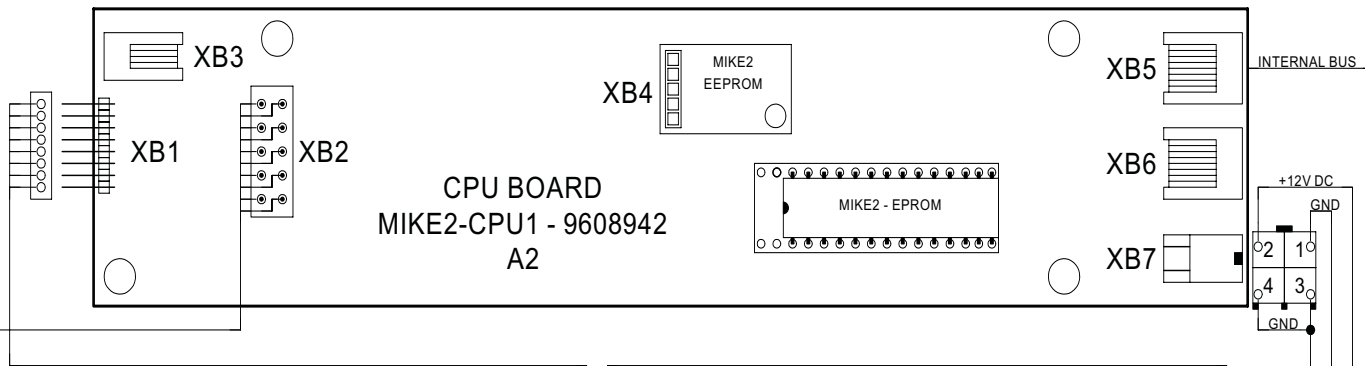
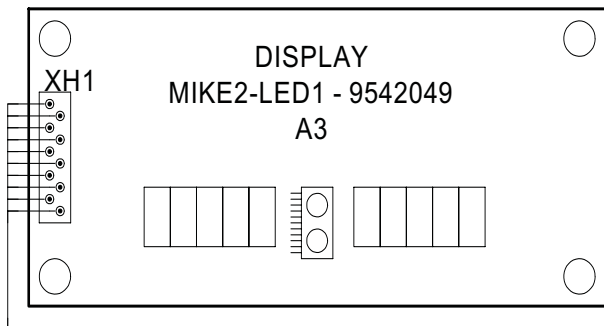

RELEASE FOR PRODUCTION	04/01/2005	LST
RELEASE ON SUPPLY	04/01/2005	LST
LAST DRAWER	03/21/2005	LST
REVISION		

WIRING DIAGRAM



FV130.2 USA
208V - 240V 3 PH+G 60Hz
ELECTRONIC CONTROL

9545585

FV130.2

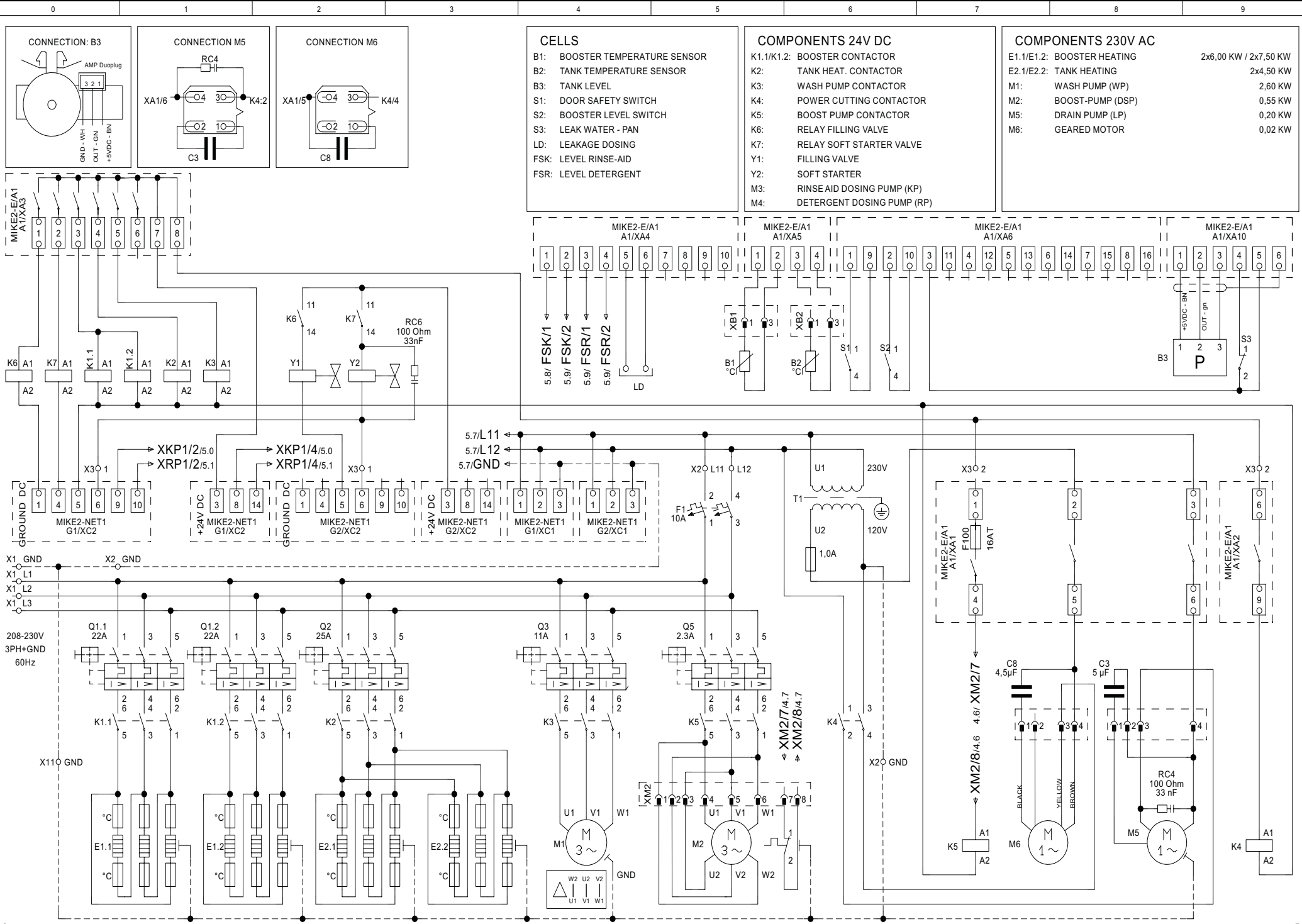

RELEASE FOR PRODUCTION	04/01/2005	LST
RELEASE ON SUPPLY	04/01/2005	LST
LAST DRAWER	03/21/2005	LST
REVISION		

WIRING DIAGRAM



FV130.2 USA
208V - 240V 3 PH+G 60Hz
ELECTRONIC CONTROL

9545585
FV130.2
Page 4

INTERNAL DOSING PUMPS - 24VDC

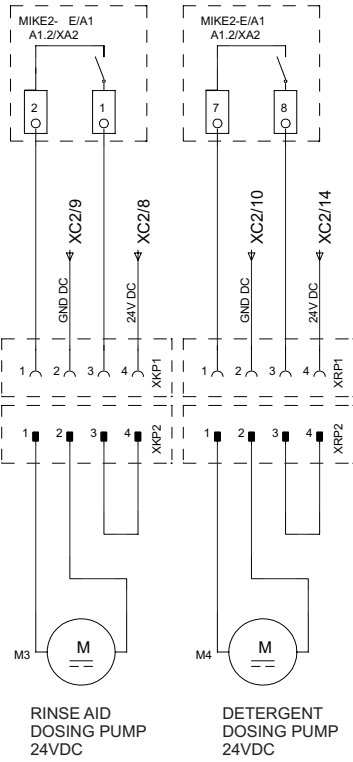

EXTERNAL DOSING PUMPS - LINE VOLTAGE

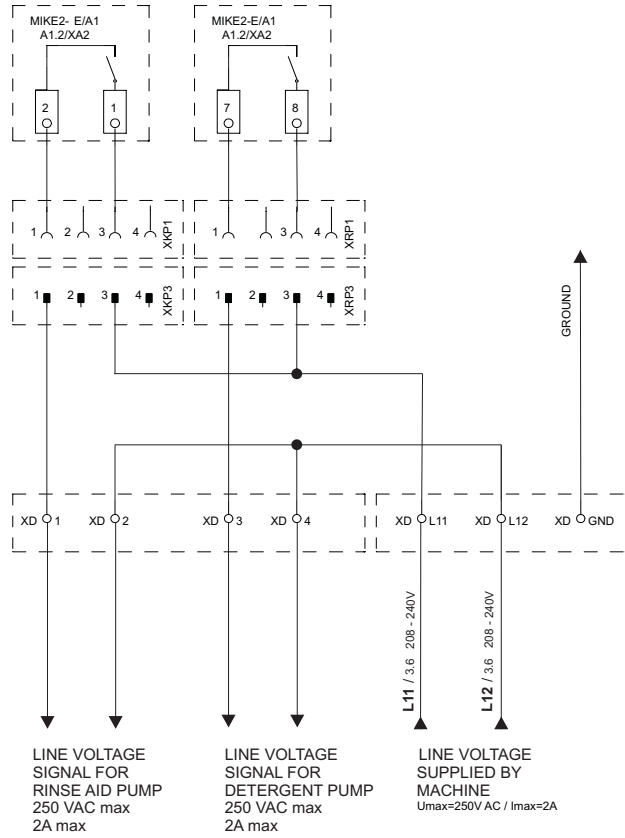

CHEMICAL AGENT LEVEL SENSOR (OPTIONAL)

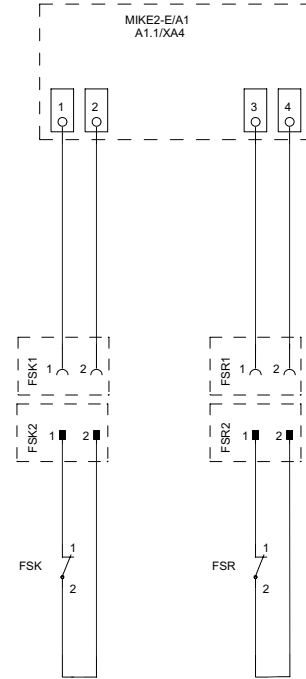

CHEMICAL AGENT LEVEL SENSOR (OPTIONAL)

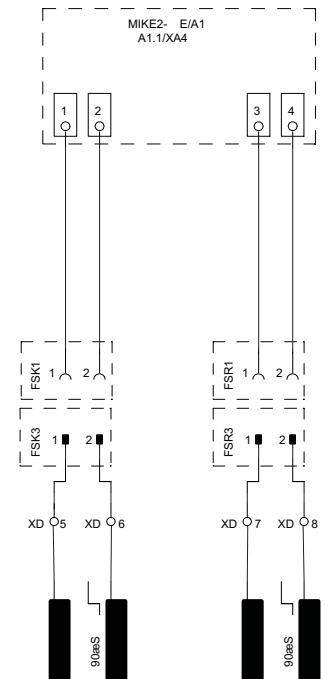

4

RELEASE FOR PRODUCTION	04/01/2005	LST
RELEASE ON SUPPLY	04/01/2005	LST
LAST DRAWER	03/21/2005	LST
REVISION		

WIRING DIAGRAM



FV130.2 USA
208V - 240V 3 PH+G 60Hz
CHEMICAL DOSING CONNECTIONS

EXTERNAL VENT FAN CONTROL

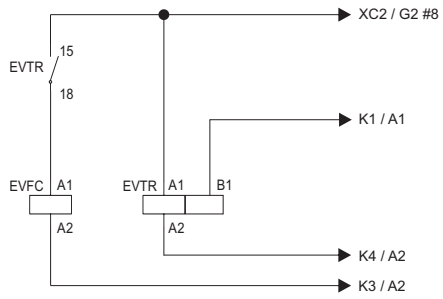

LINE VOLTAGE FOR EXHAUST FAN - IN*

LINE VOLTAGE TO EXHAUST FAN - OUT*

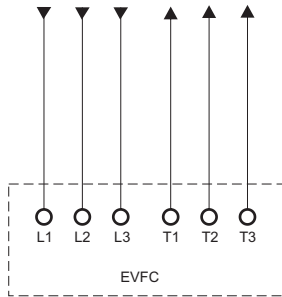

EVFC

* 12 AWG 20A MAXIMUM

EVTR TIMER SETTINGS - DIAL STYLE

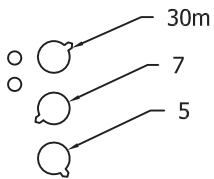

EVTR TIMER SETTINGS - DIP SWITCH STYLE



SET TO 80 %

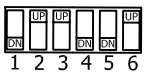

SET DIP SWITCHES TO:

- 1 - DOWN
- 2 - UP
- 3 - UP
- 4 - DOWN
- 5 - DOWN
- 6 - UP

WASH TANK FILL

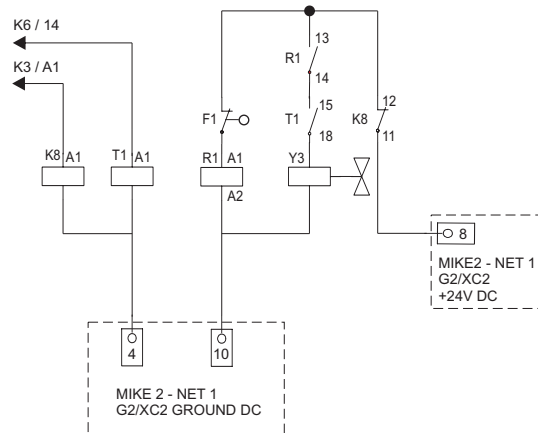

- F1: WASH TANK FLOAT
- K8: ANTI CHATTER RELAY
- R1: WASH TANK FILL RELAY
- T1: OFF DELAY TIMER WASH TANK FILL (SET TO 30 SECONDS)
- Y3: WASH TANK FILLING VALVE

5

RELEASE FOR PRODUCTION	04/01/2005	LST	
RELEASE ON SUPPLY	04/01/2005	LST	
LAST DRAWER	03/21/2005	LST	
REVISION			

WIRING DIAGRAM



FV130.2 USA
208V - 240V 3 PH+G 60Hz
CHEMICAL DOSING CONNECTIONS

9545585

FV130.2