

**Meiko USA**  
 1349 Heil Quaker Blvd.  
 Lavergne, TN 37086  
 800-868-3840

**WIRING DIAGRAM**

Model Number : DV80.2T TALL HOOD

Voltage : 460 VAC 60 HZ

Phase : 3~

Released For Production :

Editor : sz

**FOR USE WITH THE FOLLOWING OPTIONS:**

- Internal Chemical Dosing Pumps
- Drain Water Tempering Kit
- Power Cord Kit
- External Vent Fan Control

RELEASE FOR PRODUCTION	04/01/2005	LST	
RELEASE ON SUPPLY	04/01/2005	LST	
LAST DRAWER	10/22/2009	SZ	
REVISION			

WIRING DIAGRAM



DV80.2T  
 460V 3 PH+G 60Hz  
 COVER PAGE

9643835

DV80.2T

INPUT / OUTPUT ALLOCATION TABLE

LEVEL	INPUT / OUTPUT	ASSIGNMENT	CONNECTION
2-2	INPUT 1	S1: DOOR SAFETY SWITCH	XA6 1/9
2-2	INPUT 2	S2: BOOSTER LEVEL SWITCH	XA6 2/10
2-2	INPUT 3	S3: FLOOR LEAKAGE SWITCH	XA6 3
2-2	INPUT 4		XA6 4/12
2-2	INPUT 5		XA6 5/13
2-2	INPUT 6		XA6 6/14
2-2	INPUT 7		XA6 7/15
2-2	INPUT 8		XA6 8/16
2-2	INPUT 9	FSK: RINSE AID LEVEL (OPT.)	XA4 1/2
2-2	INPUT 10	FSR: DETERGENT LEVEL (OPT.)	XA4 3/4
2-2	INPUT 11		XA4 5/6
2-2	INPUT 12		XA4 7/8
2-2	INPUT 22		XA4 9/10
2-2	INPUT 19	B1: BOOSTER TEMPERATURE SENSOR	XA5 1/2
2-2	INPUT 20	B2: TANK TEMPERATURE SENSOR	XA5 3/4
2-2	INPUT 21	B3: TANK LEVEL	XA10 1/2/3
2-3	OUTPUT 1	K3: WASH PUMP CONTACTOR	XA1 4
2-3	OUTPUT 2	K4: BOOST PUMP CONTACTOR	XA1 5
2-3	OUTPUT 3	K5: DRAIN PUMP CONTACTOR	XA1 6
2-3	OUTPUT 4	M3: RINSE AID DOSING (KP)	XA2 2
2-3	OUTPUT 5	M4: DETERGENT DOSING (RP)	XA2 7
2-3	OUTPUT 6		XA2 9
2-3	OUTPUT 7	Y1: FILLING VALVE	XA3 1
2-3	OUTPUT 8	Y2: SOFT START VALVE	XA3 2
2-3	OUTPUT 9	K1: BOOSTER HEATING CONTACTOR	XA3 3
2-3	OUTPUT 10	K2: TANK HEATING CONTACTOR	XA3 4
2-3	OUTPUT 11		XA3 5
2-3	OUTPUT 12		XA3 6

RELEASE FOR PRODUCTION	04/01/2005	LST	
RELEASE ON SUPPLY	04/01/2005	LST	
LAST DRAWER	03/21/2005	LST	
REVISION			

WIRING DIAGRAM



DV80.2T  
460V 3 PH+G 60Hz  
ALLOCATION TABLE

9643835	
DV80.2T	Page 2

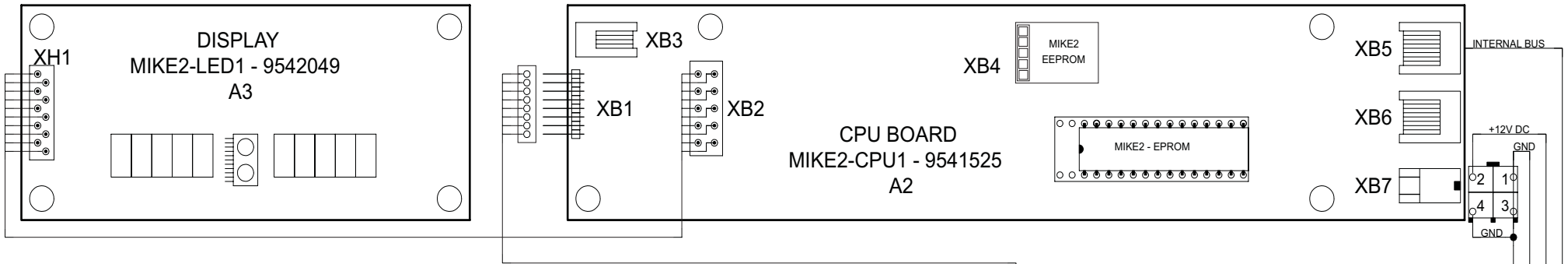

TOUCH PANEL  
PART NUMBER: 9207357  
A4

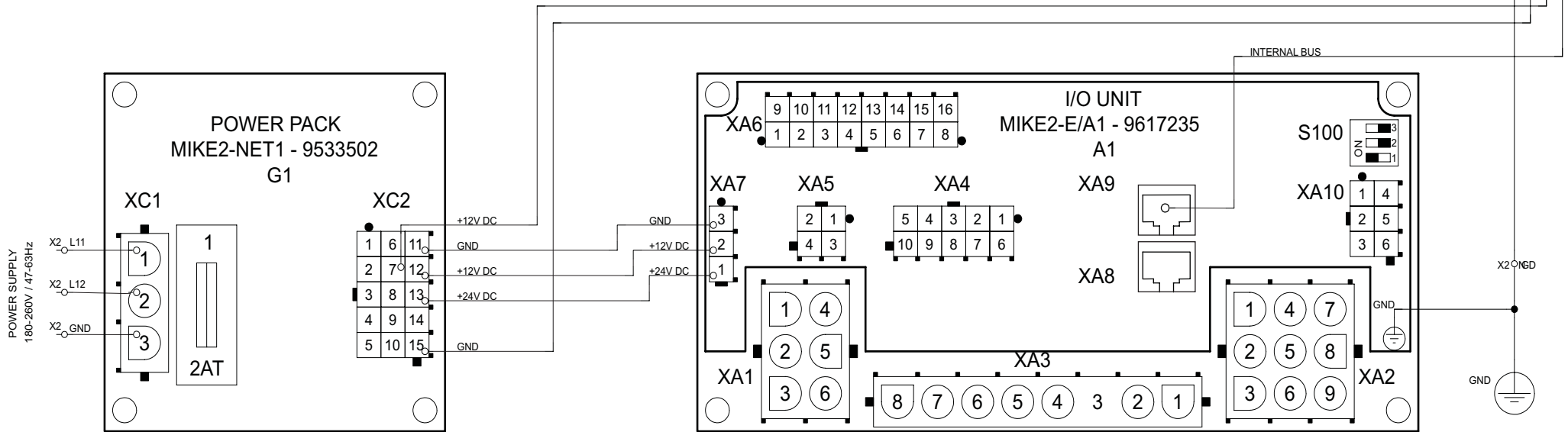

RELEASE FOR PRODUCTION	04/01/2005	LST	
RELEASE ON SUPPLY	04/01/2005	LST	
LAST DRAWER	03/21/2005	LST	
REVISION			

WIRING DIAGRAM



DV80.2T  
460V 3 PH+G 60Hz  
ELECTRONIC CONTROL

9643835  
DV80.2T

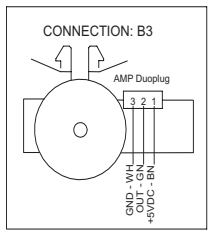

- ### SENSORS
- B1: BOOSTER TEMPERATURE SENSOR
  - B2: TANK TEMPERATURE SENSOR
  - B3: TANK LEVEL
  - B4: BOOSTER HIGH LIMIT SWITCH
  - S1: DOOR SAFETY SWITCH
  - S2: BOOSTER LEVEL SWITCH
  - S3: FLOOR LEAKAGE SWITCH
  - S6: INTELLISTART SWITCH (OPTIONAL)
  - FSK: LEVEL RINSE-AID
  - FSR: LEVEL DETERGENT

- ### COMPONENTS 24V DC
- K1: BOOSTER HEATING CONTACTOR
  - K2: TANK HEATING CONTACTOR
  - K3: WASH PUMP CONTACTOR
  - K4: BOOST PUMP CONTACTOR
  - K5: DRAIN PUMP CONTACTOR
  - Y1: FILLING VALVE
  - Y2: SOFT START VALVE
  - M3: RINSE AID DOSING (KP)
  - M4: DETERGENT DOSING (RP)

- ### COMPONENTS 440-480V AC
- E1: BOOSTER HEATING 9,00 KW
  - E2.1: TANK HEATING 2,00 KW
  - E2.2: TANK HEATING 2,00 KW
  - E2.3: TANK HEATING 2,00 KW
  - M1: WASH PUMP (WP) 1,50 KW
  - M2: BOOST-PUMP (DSP) 0,16 KW
  - M5: DRAIN PUMP (LP) 0,09 KW

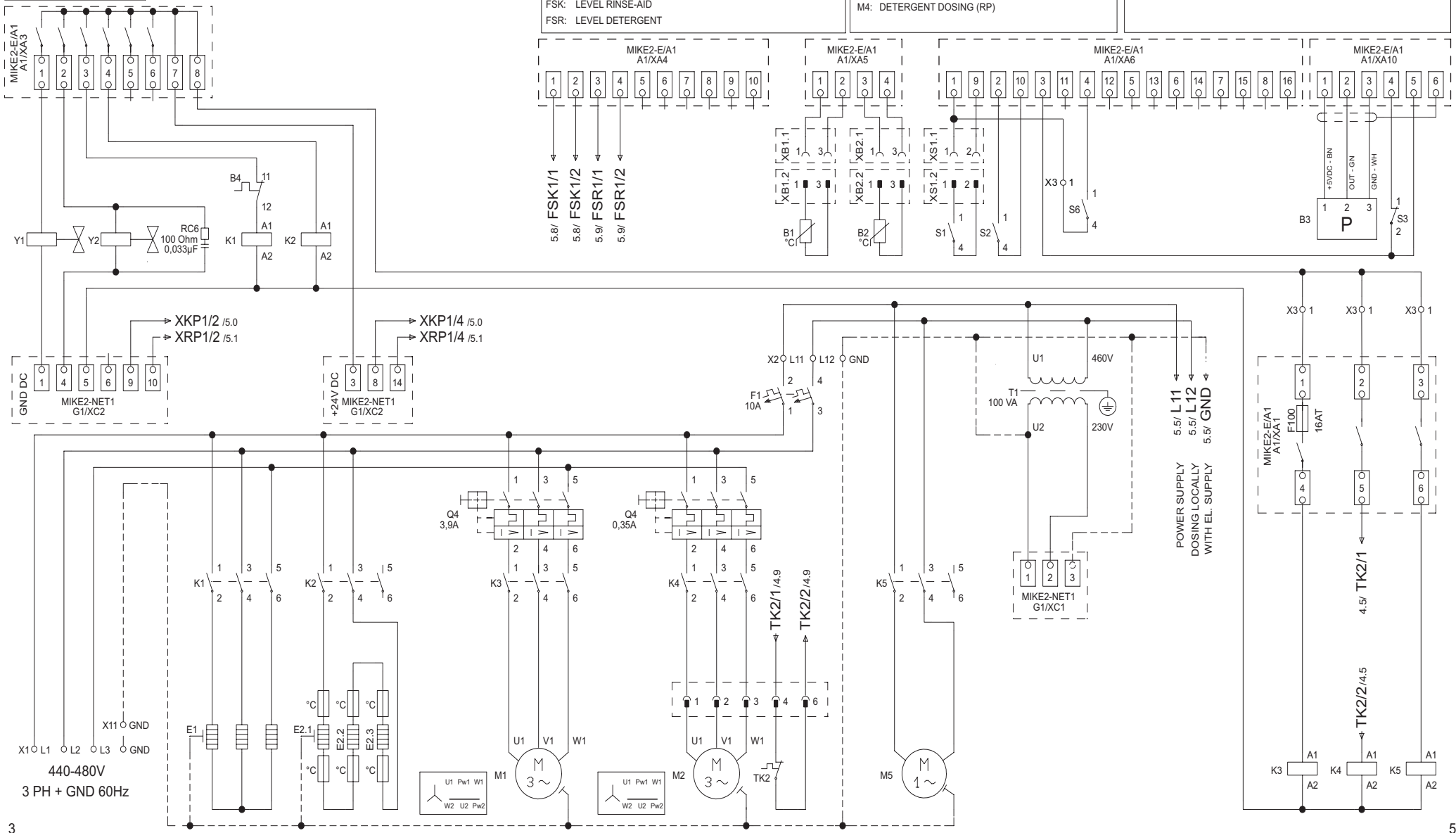

RELEASE FOR PRODUCTION	04/01/2005	LST
RELEASE ON SUPPLY	04/01/2005	LST
LAST DRAWER	03/21/2005	LST
REVISION		

WIRING DIAGRAM



DV80.2T  
460V 3 PH+G 60Hz  
ELECTRONIC CONTROL

9643835	
DV80.2T	Page 4

INTERNAL DOSING PUMPS - 24VDC

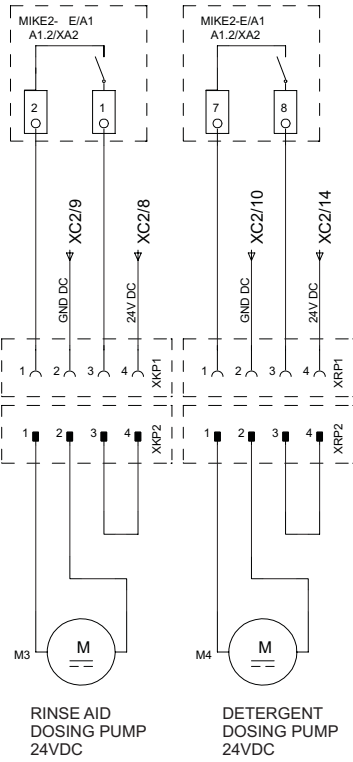

EXTERNAL DOSING PUMPS - LINE VOLTAGE

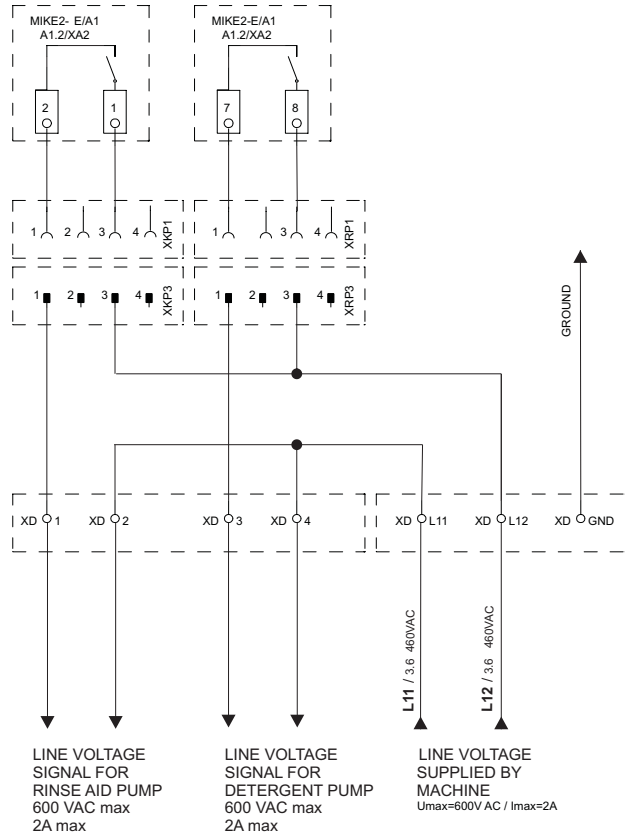

CHEMICAL AGENT LEVEL SENSOR (OPTIONAL)

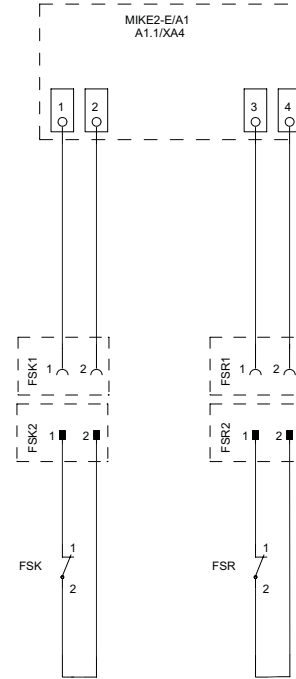

CHEMICAL AGENT LEVEL SENSOR (OPTIONAL)

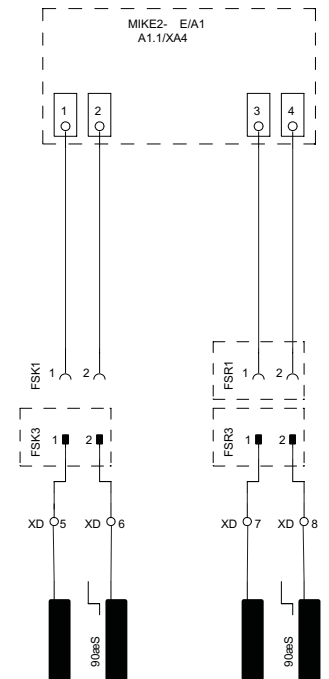

4

RELEASE FOR PRODUCTION	04/01/2005	LST
RELEASE ON SUPPLY	04/01/2005	LST
LAST DRAWER	03/21/2005	LST
REVISION		

WIRING DIAGRAM



DV80.2T  
460V 3 PH+G 60Hz  
CHEMICAL DOSING CONNECTIONS

9643835

DV80.2T

EXTERNAL VENT FAN CONTROL

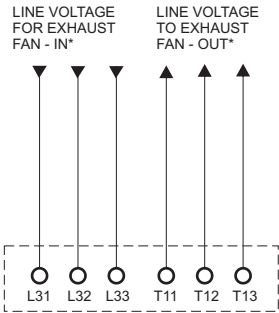
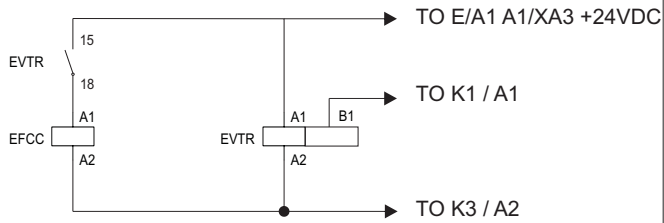

\* 12 AWG 20A MAXIMUM

EVTR TIMER SETTINGS - DIAL STYLE

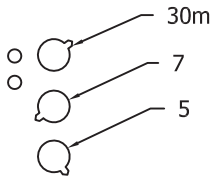

EVTR TIMER SETTINGS - DIP SWITCH STYLE



SET TO 80 %

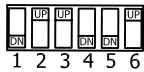

SET DIP SWITCHES TO:

- 1 - DOWN
- 2 - UP
- 3 - UP
- 4 - DOWN
- 5 - DOWN
- 6 - UP

5

RELEASE FOR PRODUCTION	04/01/2005	LST	
RELEASE ON SUPPLY	04/01/2005	LST	
LAST DRAWER	03/21/2005	LST	
REVISION			

WIRING DIAGRAM



DV80.2T  
460V 3 PH+G 60Hz  
CHEMICAL DOSING CONNECTIONS

9643835

DV80.2T