

Meiko USA
 1349 Heil Quaker Blvd.
 Lavergne, TN 37086
 800-868-3840

WIRING DIAGRAM

Model Number : DV80.2T TALL HOOD

Voltage : 208V - 240VAC 60 HZ

Phase : 1~

Released For Production :

Editor :

FOR USE WITH THE FOLLOWING OPTIONS:

- Internal Chemical Dosing Pumps
- Drain Water Tempering Kit
- Power Cord Kit
- External Vent Fan Control

| | | | |
|------------------------|------------|-----|--|
| RELEASE FOR PRODUCTION | 04/01/2005 | LST | |
| RELEASE ON SUPPLY | 04/01/2005 | LST | |
| LAST DRAWER | 08/16/2010 | LST | |
| REVISION | | | |

WIRING DIAGRAM



DV80.2T
 208V - 240V 1 PH+G 60Hz
 COVER PAGE

9643837

DV80.2T

INPUT / OUTPUT ALLOCATION TABLE

| LEVEL | INPUT / OUTPUT | ASSIGNMENT | CONNECTION |
|-------|----------------|--------------------------------------|------------|
| 2-2 | INPUT 1 | S1: DOOR SAFETY SWITCH | XA6 1/9 |
| 2-2 | INPUT 2 | S2: BOOSTER LEVEL SWITCH | XA6 2/10 |
| 2-2 | INPUT 3 | S3: FLOOR LEAKAGE SWITCH | XA6 3 |
| 2-2 | INPUT 4 | | XA6 4/12 |
| 2-2 | INPUT 5 | | XA6 5/13 |
| 2-2 | INPUT 6 | | XA6 6/14 |
| 2-2 | INPUT 7 | | XA6 7/15 |
| 2-2 | INPUT 8 | | XA6 8/16 |
| 2-2 | INPUT 9 | FSK: RINSE AID LEVEL (OPT.) | XA4 1/2 |
| 2-2 | INPUT 10 | FSR: DETERGENT LEVEL (OPT.) | XA4 3/4 |
| 2-2 | INPUT 11 | | XA4 5/6 |
| 2-2 | INPUT 12 | | XA4 7/8 |
| 2-2 | INPUT 22 | | XA4 9/10 |
| 2-2 | INPUT 19 | B1: BOOSTER TEMPERATURE SENSOR | XA5 1/2 |
| 2-2 | INPUT 20 | B2: TANK TEMPERATURE SENSOR | XA5 3/4 |
| 2-2 | INPUT 21 | B3: TANK LEVEL | XA10 1/2/3 |
| 2-3 | OUTPUT 1 | K4: WASH PUMP CONTACTOR | XA1 4 |
| 2-3 | OUTPUT 2 | M2: BOOST-PUMP (DSP) | XA1 5 |
| 2-3 | OUTPUT 3 | M5: DRAIN PUMP (LP) | XA1 6 |
| 2-3 | OUTPUT 4 | M3: RINSE AID DOSING (KP) | XA2 2 |
| 2-3 | OUTPUT 5 | M4: DETERGENT DOSING (RP) | XA2 7 |
| 2-3 | OUTPUT 6 | K3: POWER CUTTING CONTACTOR | XA2 9 |
| 2-3 | OUTPUT 7 | Y1: FILLING VALVE | XA3 1 |
| 2-3 | OUTPUT 8 | Y2: SOFT START VALVE | XA3 2 |
| 2-3 | OUTPUT 9 | K1.1/K1.2: BOOSTER HEATING CONTACTOR | XA3 3 |
| 2-3 | OUTPUT 10 | K2: TANK HEATING CONTACTOR | XA3 4 |
| 2-3 | OUTPUT 11 | | XA3 5 |
| 2-3 | OUTPUT 12 | | XA3 6 |

| | | | |
|------------------------|------------|-----|--|
| RELEASE FOR PRODUCTION | 04/01/2005 | LST | |
| RELEASE ON SUPPLY | 04/01/2005 | LST | |
| LAST DRAWER | 08/16/2010 | LST | |
| REVISION | | | |

WIRING DIAGRAM



DV80.2T
208V - 240V 1 PH+G 60Hz
ALLOCATION TABLE

9643837
DV80.2T

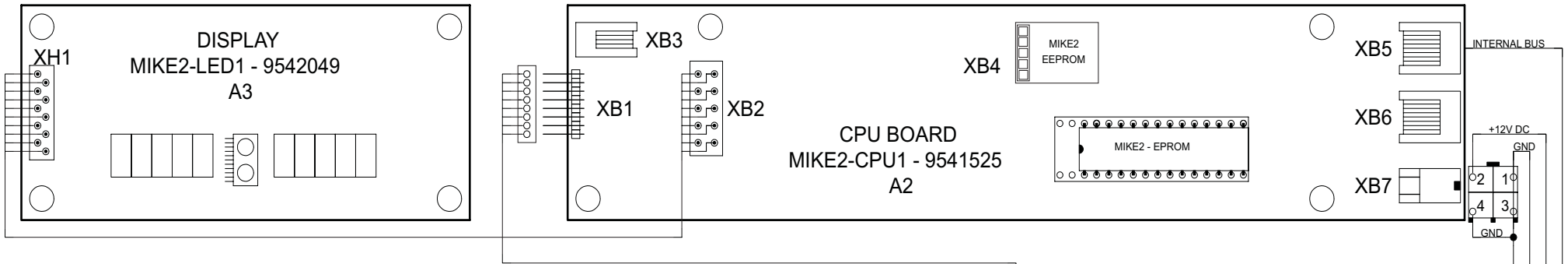

TOUCH PANEL
PART NUMBER: 9207357
A4

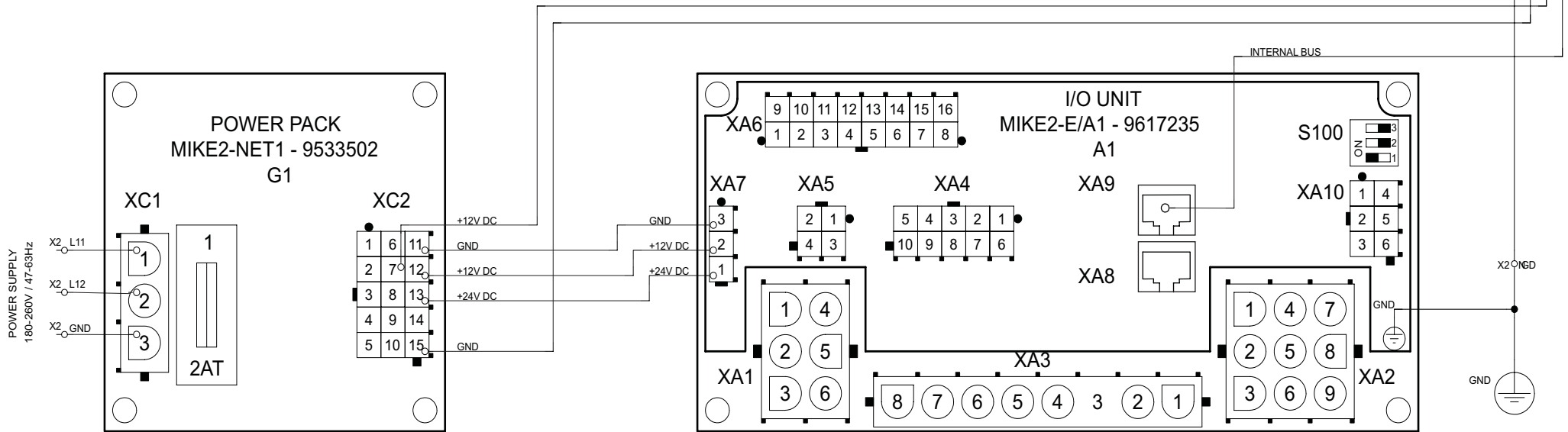

| | | |
|------------------------|------------|-----|
| RELEASE FOR PRODUCTION | 04/01/2005 | LST |
| RELEASE ON SUPPLY | 04/01/2005 | LST |
| LAST DRAWER | 08/16/2010 | LST |
| REVISION | | |

WIRING DIAGRAM



DV80.2T
208V - 240V 1 PH+G 60Hz
ELECTRONIC CONTROL

9643837
DV80.2T

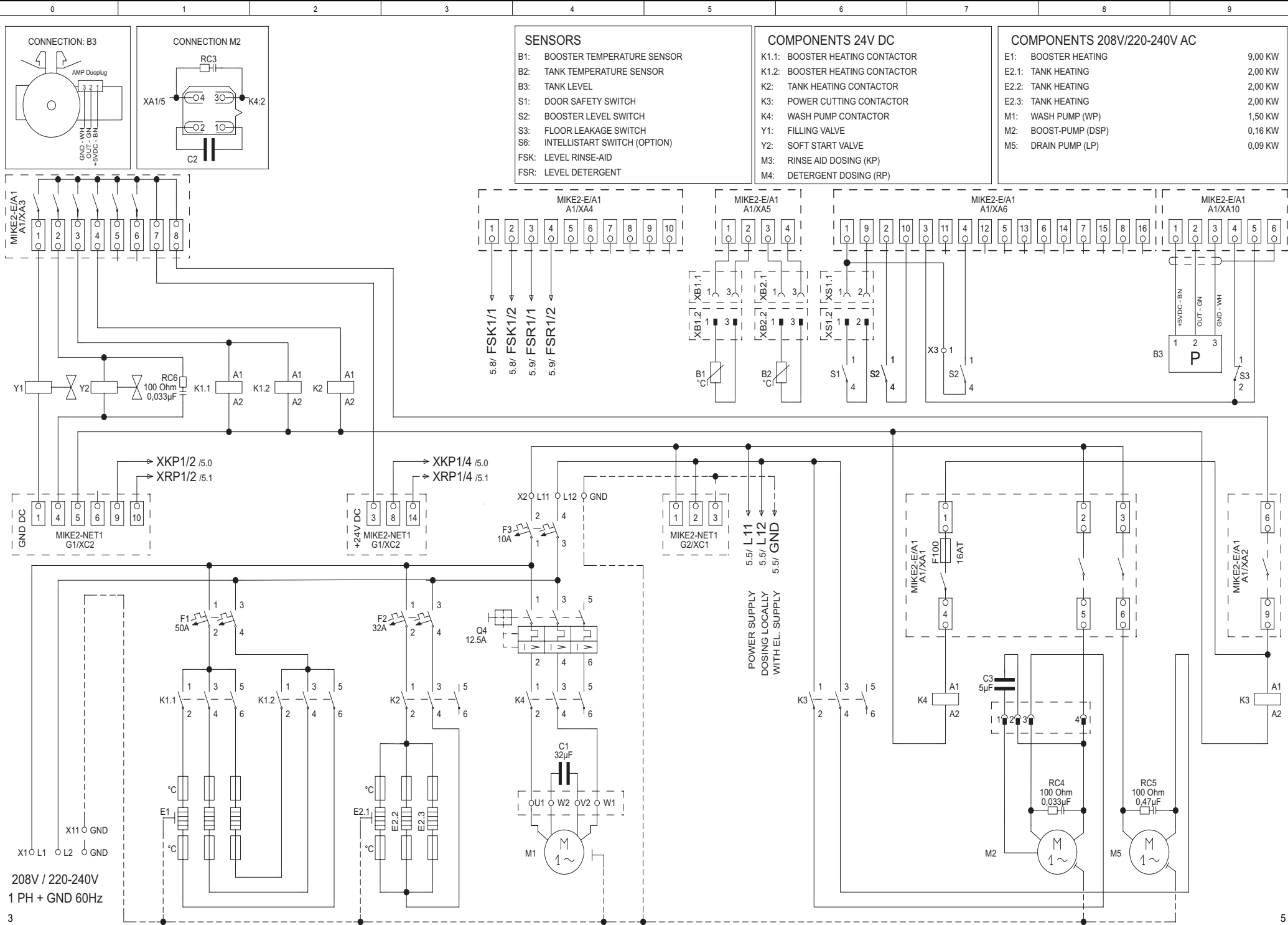

| | | |
|------------------------|------------|-----|
| RELEASE FOR PRODUCTION | 04/01/2005 | LST |
| RELEASE ON SUPPLY | 04/01/2005 | LST |
| LAST DRAWER | 08/16/2010 | LST |
| REVISION | | |

WIRING DIAGRAM



DV80.2T
208V - 240V 1 PH+G 60Hz
ELECTRONIC CONTROL

9643837
DV80.2T
Page 4

INTERNAL DOSING PUMPS - 24VDC

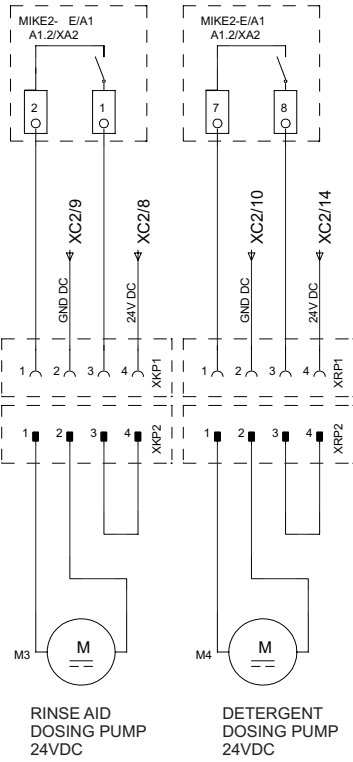

EXTERNAL DOSING PUMPS - LINE VOLTAGE

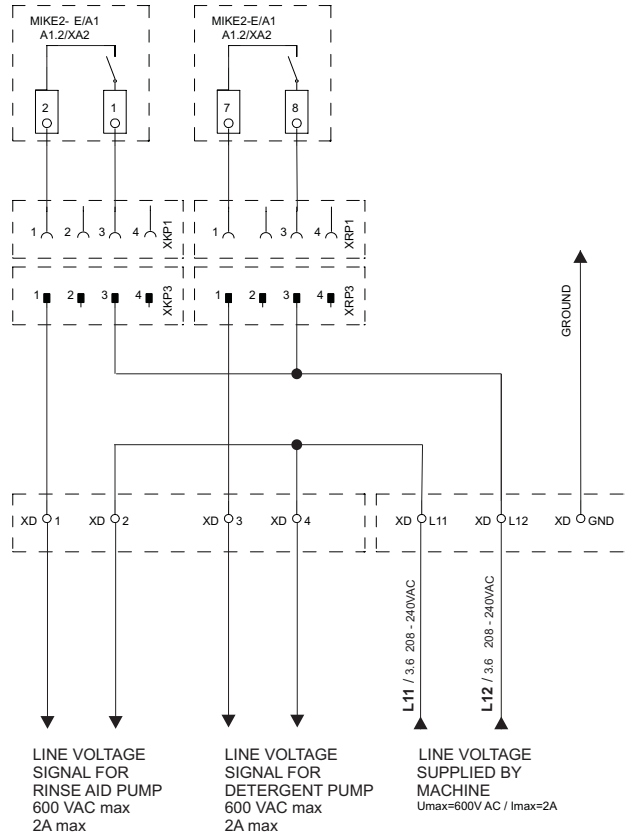

CHEMICAL AGENT LEVEL SENSOR (OPTIONAL)

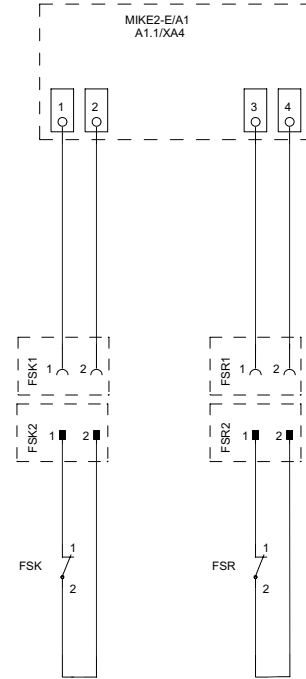

CHEMICAL AGENT LEVEL SENSOR (OPTIONAL)

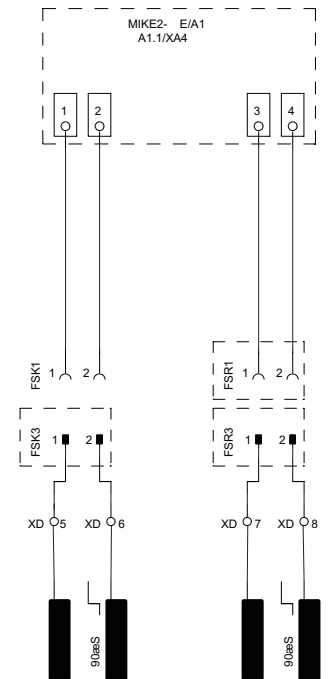

4

| | | |
|------------------------|------------|-----|
| RELEASE FOR PRODUCTION | 04/01/2005 | LST |
| RELEASE ON SUPPLY | 04/01/2005 | LST |
| LAST DRAWER | 08/16/2010 | LST |
| REVISION | | |

WIRING DIAGRAM



DV80.2T
208V - 240V 1 PH+G 60Hz
CHEMICAL DOSING CONNECTIONS

9643837
DV80.2T
Page 5

EXTERNAL VENT FAN CONTROL

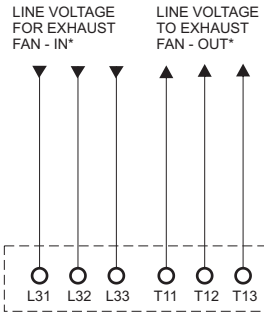
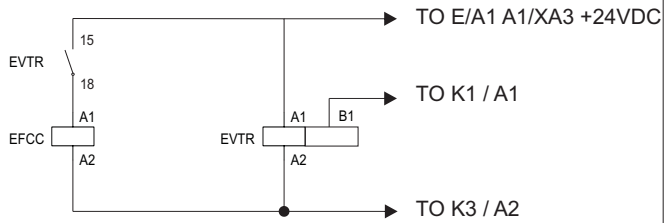

* 12 AWG 20A MAXIMUM

EVTR TIMER SETTINGS - DIAL STYLE

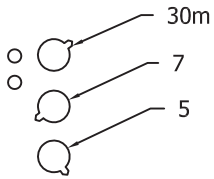

EVTR TIMER SETTINGS - DIP SWITCH STYLE



SET TO 80 %

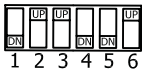

SET DIP SWITCHES TO:

- 1 - DOWN
- 2 - UP
- 3 - UP
- 4 - DOWN
- 5 - DOWN
- 6 - UP

5

| | | | |
|------------------------|------------|-----|--|
| RELEASE FOR PRODUCTION | 04/01/2005 | LST | |
| RELEASE ON SUPPLY | 04/01/2005 | LST | |
| LAST DRAWER | 08/16/2010 | LST | |
| REVISION | | | |

WIRING DIAGRAM



DV80.2T
208V - 240V 1 PH+G 60Hz
CHEMICAL DOSING CONNECTIONS

9643837

DV80.2T