

Meiko USA
 1349 Heil Quaker Blvd.
 Lavergne, TN 37086
 800-868-3840

WIRING DIAGRAM

Model Number : DV80.2 ENERGY STAR

Voltage : 208V - 240VAC 60 HZ

Phase : 1~

Released For Production :

Editor : SZ

FOR USE WITH THE FOLLOWING OPTIONS:

- Internal Chemical Dosing Pumps
- Drain Water Tempering Kit
- Power Cord Kit
- External Vent Fan Control

RELEASE FOR PRODUCTION	07/09/2010	LST	
RELEASE ON SUPPLY	07/09/2010	LST	
LAST DRAWER	07/09/2010	LST	
REVISION			

WIRING DIAGRAM



DV80.2 ENERGY STAR V2
 208V - 240V 1 PH+G 60Hz
 COVER PAGE

9677514

DV80.2

INPUT / OUTPUT ALLOCATION TABLE

LEVEL	INPUT / OUTPUT	ASSIGNMENT	CONNECTION
2-2	INPUT 1	S1: DOOR CLOSED	XA6 1/9
2-2	INPUT 2	S2: BOOSTER LEVEL SWITCH	XA6 2/10
2-2	INPUT 3	S3: FLOOR LEAKAGE	XA6 3
2-2	INPUT 4	S4: HOOD HANDLE START	XA6 4/12
2-2	INPUT 5		XA6 5/13
2-2	INPUT 6		XA6 6/14
2-2	INPUT 7		XA6 7/15
2-2	INPUT 8		XA6 8/16
2-2	INPUT 9	FSK: RINSE AID LEVEL (OPT.)	XA4 1/2
2-2	INPUT 10	FSR: DETERGENT LEVEL (OPT.)	XA4 3/4
2-2	INPUT 11		XA4 5/6
2-2	INPUT 12		XA4 7/8
2-2	INPUT 22		XA4 9/10
2-2	INPUT 19	B1: BOOSTER TEMPERATURE	XA5 1/2
2-2	INPUT 20	B2: TANK TEMPERATURE	XA5 3/4
2-2	INPUT 21	B3: TANK LEVEL	XA10 1/2/3
2-3	OUTPUT 1	M1: WASH PUMP	XA1 4
2-3	OUTPUT 2	M2: BOOST-PUMP	XA1 5
2-3	OUTPUT 3	M5: DRAIN PUMP	XA1 6
2-3	OUTPUT 4	M3/KP: RINSE AID DOSING	XA2 2
2-3	OUTPUT 5	M4/RP: DETERGENT DOSING	XA2 7
2-3	OUTPUT 6	K3: POWER CUTTING	XA2 9
2-3	OUTPUT 7	Y1: FILLING VALVE	XA3 1
2-3	OUTPUT 8	Y2: SOFT START VALVE	XA3 2
2-3	OUTPUT 9	K1: BOOSTER CONTACTOR	XA3 3
2-3	OUTPUT 10	K2: TANK HEAT. CONTACTOR	XA3 4
2-3	OUTPUT 11		XA3 5
2-3	OUTPUT 12		XA3 6

RELEASE FOR PRODUCTION	07/09/2010	LST	
RELEASE ON SUPPLY	07/09/2010	LST	
LAST DRAWER	07/09/2010	LST	
REVISION			

WIRING DIAGRAM



DV80.2 ENERGY STAR V2
208V - 240V 1 PH+G 60Hz
ALLOCATION TABLE

9677514
DV80.2

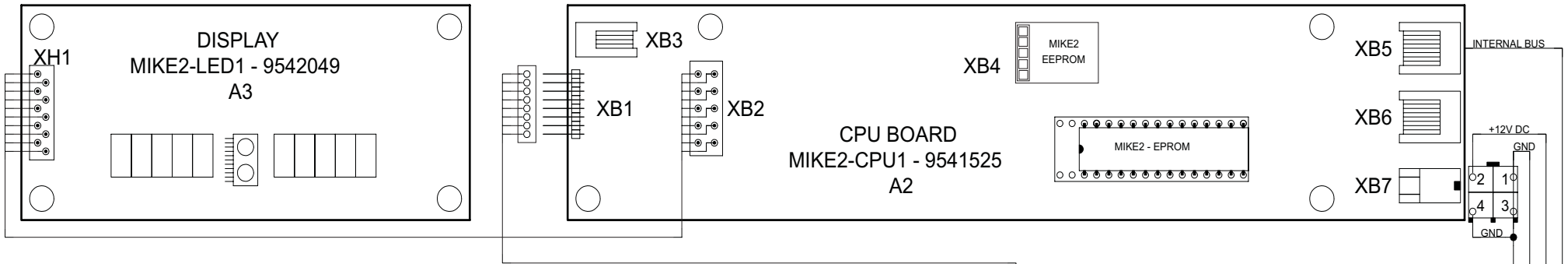

TOUCH PANEL
PART NUMBER: 9207357
A4

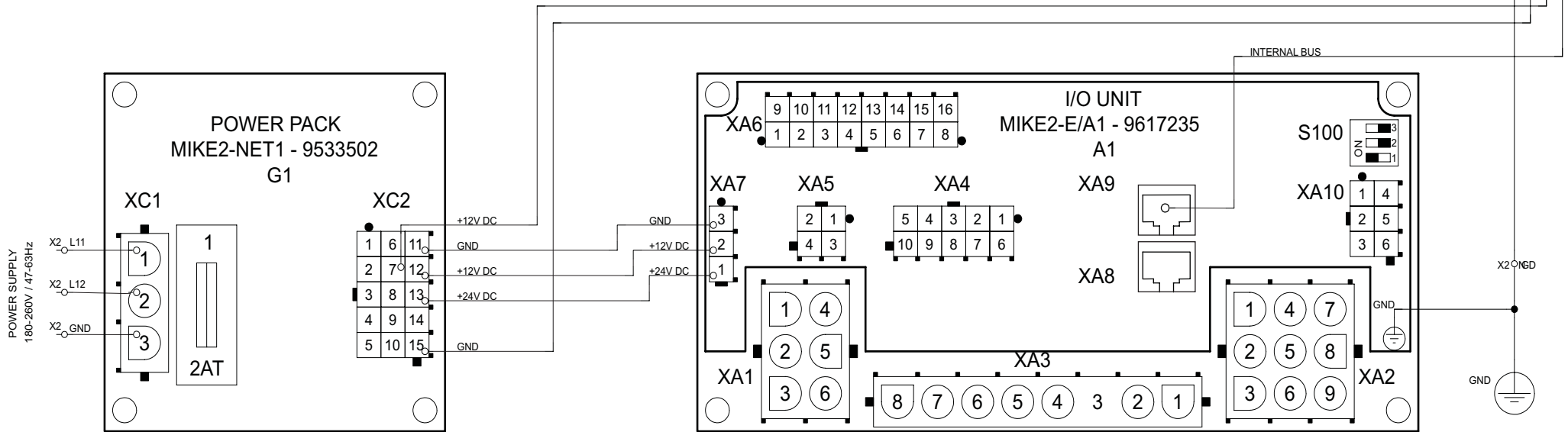

RELEASE FOR PRODUCTION	07/09/2010	LST	
RELEASE ON SUPPLY	07/09/2010	LST	
LAST DRAWER	07/09/2010	LST	
REVISION			

WIRING DIAGRAM



DV80.2 ENERGY STAR V2
208V - 240V 1 PH+G 60Hz
ELECTRONIC CONTROL

9677514

DV80.2

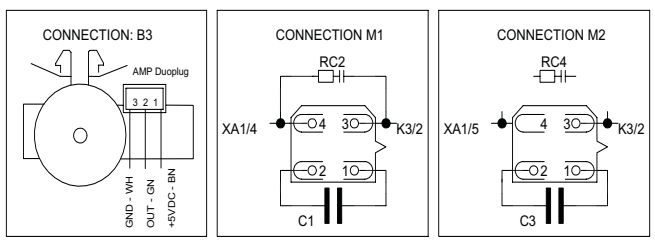

- ### CELLS
- B1: TANK TEMPERATURE SENSOR
 - B2: TANK LEVEL SWITCH
 - B3: TANK LEVEL SWITCH
 - S1: DOOR SAFETY SWITCH
 - S2: BOOSTER LEVEL SWITCH
 - S3: FLOOR LEAKAGE SWITCH
 - S4: HOOD HANDLE START
 - FSK: RINSE AID LEVEL (OPT.)
 - FSR: DETERGENT LEVEL (OPT.)

- ### COMPONENTS 24V DC
- K1.1: BOOSTER CONTACTOR
 - K1.2: BOOSTER CONTACTOR
 - K2: TANK HEAT CONTACTOR
 - K3: POWER CUTTING CONTACTOR
 - Y1: FILLING VALVE
 - Y2: SOFT START
 - M3: RINSE AID DOSING PUMP (KP)
 - M4: DETERGENT DOSING PUMP (RP)

- ### COMPONENTS 208V/220-240V AC
- E1: BOOSTER HEATING 9.00 KW
 - E2.1: TANK HEATING 3.00 KW
 - E2.2: TANK HEATING 3.00 KW
 - M1: WASH PUMP (WP) 0.75 KW
 - M2: BOOST-PUMP (DSP) 0.20 KW
 - M5: DRAIN PUMP (LP) 0.10 KW

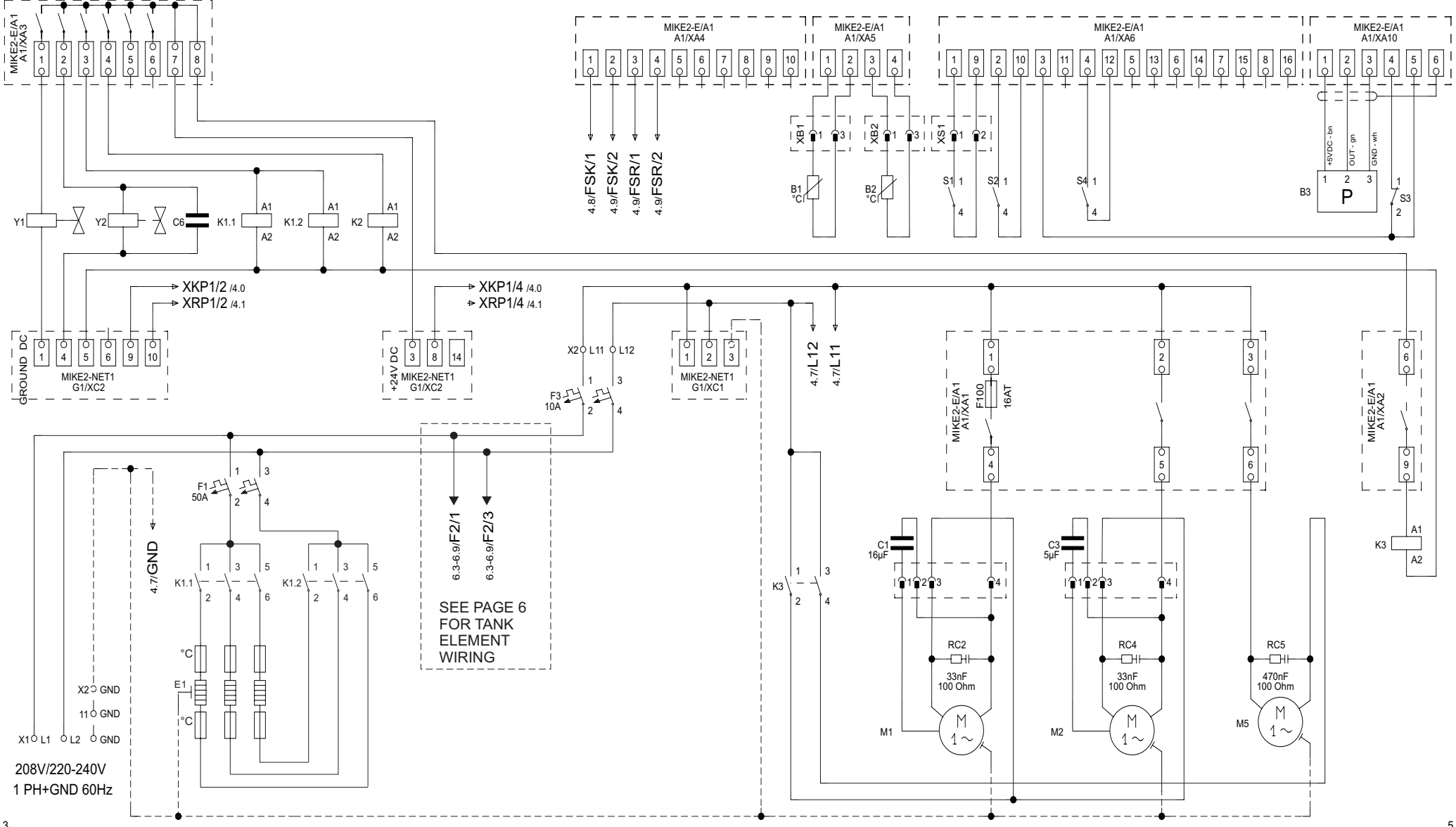

SEE PAGE 6 FOR TANK ELEMENT WIRING

RELEASE FOR PRODUCTION	07/09/2010	LST
RELEASE ON SUPPLY	07/09/2010	LST
LAST DRAWER	07/09/2010	LST
REVISION		

WIRING DIAGRAM



DV80.2 ENERGY STAR V2
208V - 240V 1 PH+G 60Hz
ELECTRONIC CONTROL

9677514
DV80.2
Page 4

INTERNAL DOSING PUMPS - 24VDC

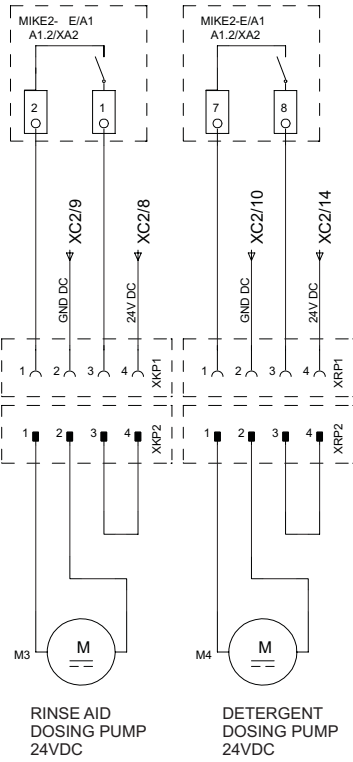

EXTERNAL DOSING PUMPS - LINE VOLTAGE

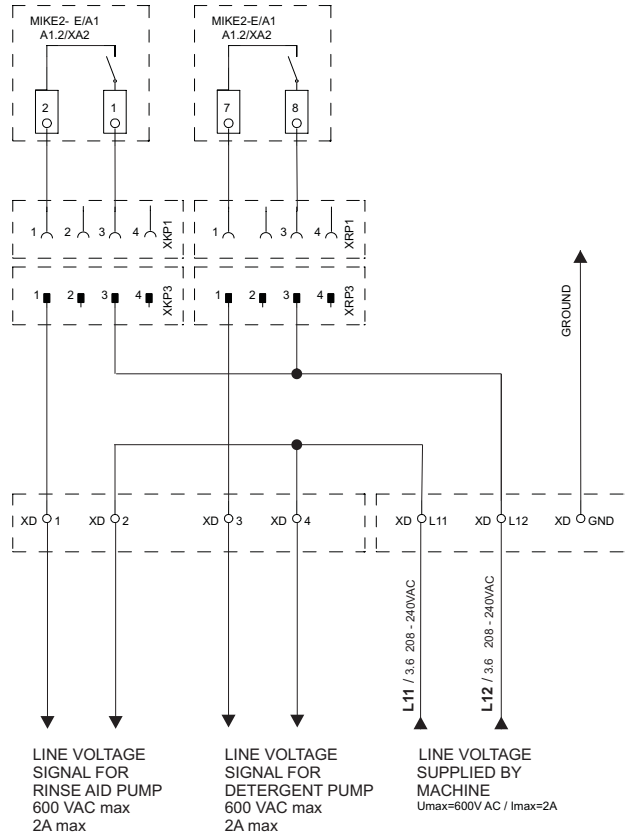

CHEMICAL AGENT LEVEL SENSOR (OPTIONAL)

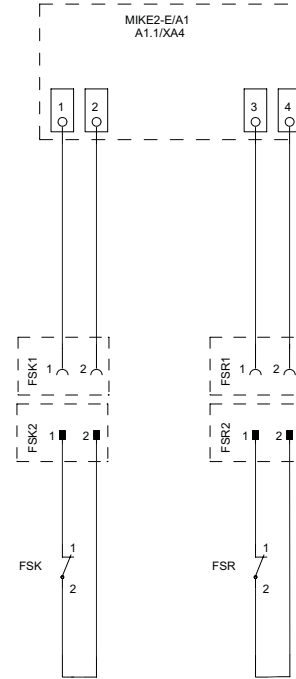

CHEMICAL AGENT LEVEL SENSOR (OPTIONAL)

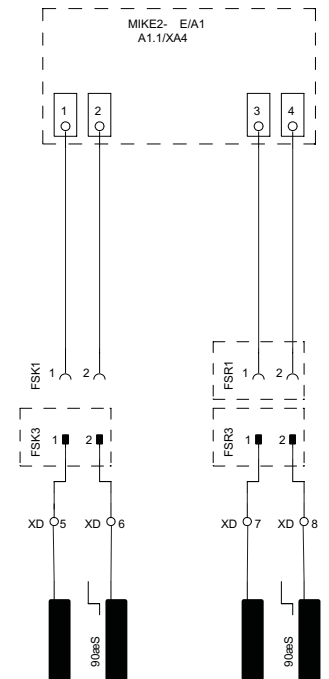

RELEASE FOR PRODUCTION	07/09/2010	LST
RELEASE ON SUPPLY	07/09/2010	LST
LAST DRAWER	07/09/2010	LST
REVISION		

WIRING DIAGRAM



DV80.2 ENERGY STAR V2
208V - 240V 1 PH+G 60Hz
CHEMICAL DOSING CONNECTIONS

9677514	
DV80.2	Page 5

EXTERNAL VENT FAN CONTROL

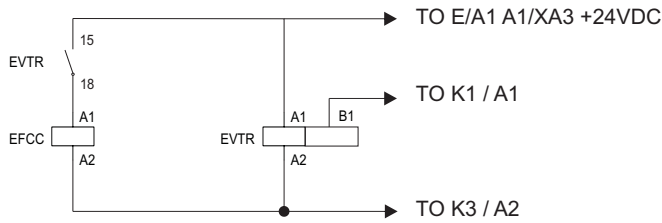

LINE VOLTAGE FOR EXHAUST FAN - IN*
LINE VOLTAGE TO EXHAUST FAN - OUT*

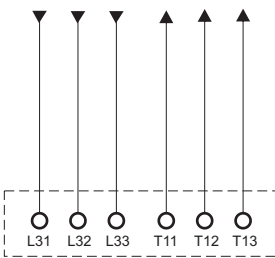

* 12 AWG 20A MAXIMUM

WASH TANK ELEMENT CONFIGURATIONS BASED ON SERIAL NUMBER

FOR UNITS WITH SERIAL NUMBER UP TO 30002714

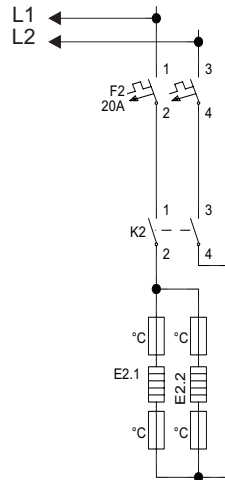

FOR UNITS WITH SERIAL NUMBER BETWEEN 30002715 - 30003007

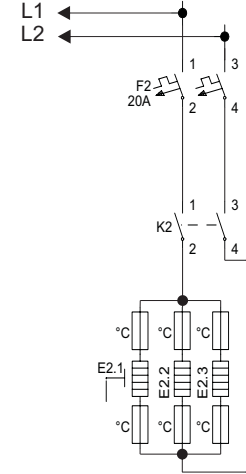

FOR UNITS WITH SERIAL NUMBER 30003008 AND ABOVE

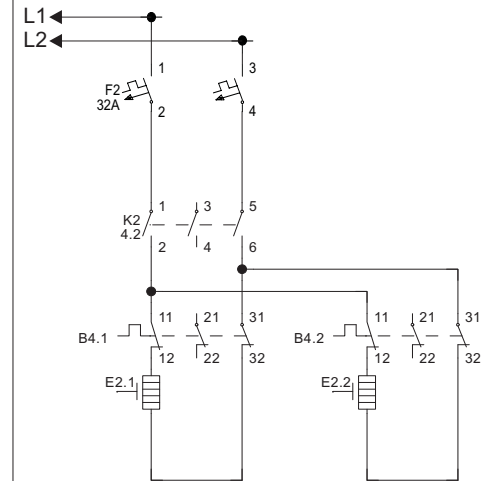

EVTR TIMER SETTINGS - DIAL STYLE

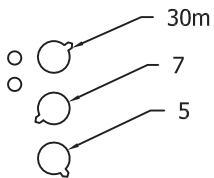

EVTR TIMER SETTINGS - DIP SWITCH STYLE



SET TO 80 %

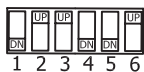

SET DIP SWITCHES TO:

- 1 - DOWN
- 2 - UP
- 3 - UP
- 4 - DOWN
- 5 - DOWN
- 6 - UP

RELEASE FOR PRODUCTION	07/09/2010	LST
RELEASE ON SUPPLY	07/09/2010	LST
LAST DRAWER	07/09/2010	LST
REVISION		

