

Meiko USA
 1349 Heil Quaker Blvd.
 Lavergne, TN 37086
 800-868-3840

WIRING DIAGRAM

Model Number : DV120.2T TALL HOOD
 Voltage : 208 - 230 VAC 60 HZ
 Phase : 3~

Released For Production :

Editor : sz

FOR USE WITH THE FOLLOWING OPTIONS:

- Internal Chemical Dosing Pumps
- Drain Water Tempering Kit
- Power Cord Kit
- External Vent Fan Control

RELEASE FOR PRODUCTION	04/01/2005	LST	
RELEASE ON SUPPLY	04/01/2005	LST	
LAST DRAWER	10/22/2009	SZ	
REVISION			

WIRING DIAGRAM



DV120.2T
 208V - 230V 3 PH+G 60Hz
 COVER PAGE

9643057

DV120.2T

INPUT / OUTPUT ALLOCATION TABLE

LEVEL	INPUT / OUTPUT	ASSIGNMENT	CONNECTION
2-2	INPUT 1	S1: DOOR CLOSED	XA6 1/9
2-2	INPUT 2	S2: BOOSTER LEVEL SWITCH	XA6 2/10
2-2	INPUT 3	S3: FLOOR LEAKAGE	XA6 3
2-2	INPUT 4	S4: HOOD HANDLE START	XA6 4/12
2-2	INPUT 5		XA6 5/13
2-2	INPUT 6		XA6 6/14
2-2	INPUT 7		XA6 7/15
2-2	INPUT 8		XA6 8/16
2-2	INPUT 9	FSK: RINSE AID LEVEL (OPT.)	XA4 1/2
2-2	INPUT 10	FSR: DETERGENT LEVEL (OPT.)	XA4 3/4
2-2	INPUT 11		XA4 5/6
2-2	INPUT 12		XA4 7/8
2-2	INPUT 22		XA4 9/10
2-2	INPUT 19	B1: BOOSTER TEMPERATURE	XA5 1/2
2-2	INPUT 20	B2: TANK TEMPERATURE	XA5 3/4
2-2	INPUT 21	B3: TANK LEVEL	XA10 1/2/3
2-3	OUTPUT 1	U1-S1: FREQUENCY CONVERTER	XA1 4
2-3	OUTPUT 2	M2: BOOST-PUMP	XA1 5
2-3	OUTPUT 3	M5: DRAIN PUMP	XA1 6
2-3	OUTPUT 4	M3/KP: RINSE AID DOSING	XA2 2
2-3	OUTPUT 5	M4/RP: DETERGENT DOSING	XA2 7
2-3	OUTPUT 6	K3/K4: POWER CUTTING	XA2 9
2-3	OUTPUT 7	Y1: FILLING VALVE	XA3 1
2-3	OUTPUT 8		XA3 2
2-3	OUTPUT 9	K1.1/.2: BOOSTER CONTACTOR	XA3 3
2-3	OUTPUT 10	K2: TANK HEAT. CONTACTOR	XA3 4
2-3	OUTPUT 11	U1-S5: FREQUENCY CONVERTER	XA3 5
2-3	OUTPUT 12	U1-S6: FREQUENCY CONVERTER	XA3 6

RELEASE FOR PRODUCTION	04/01/2005	LST	
RELEASE ON SUPPLY	04/01/2005	LST	
LAST DRAWER	03/21/2005	LST	
REVISION			

WIRING DIAGRAM



DV120.2T
208V - 230V 3 PH+G 60Hz
ALLOCATION TABLE

9643057
DV120.2T

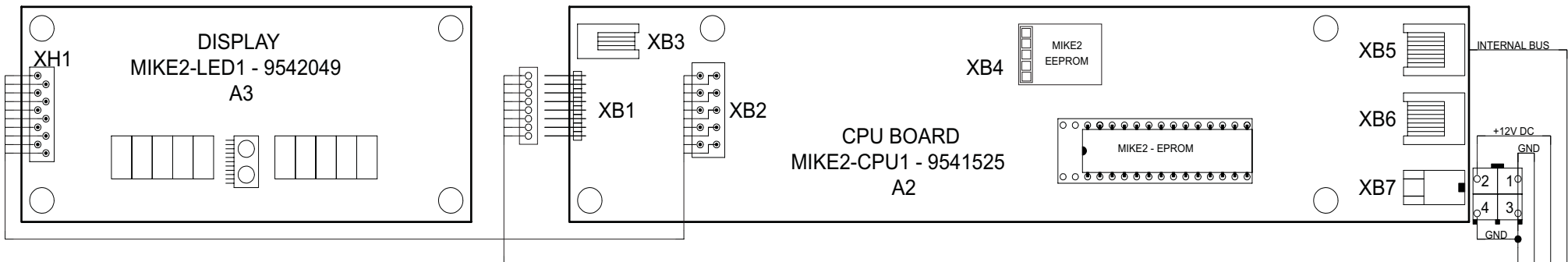

TOUCH PANEL
PART NUMBER: 9207357
A4

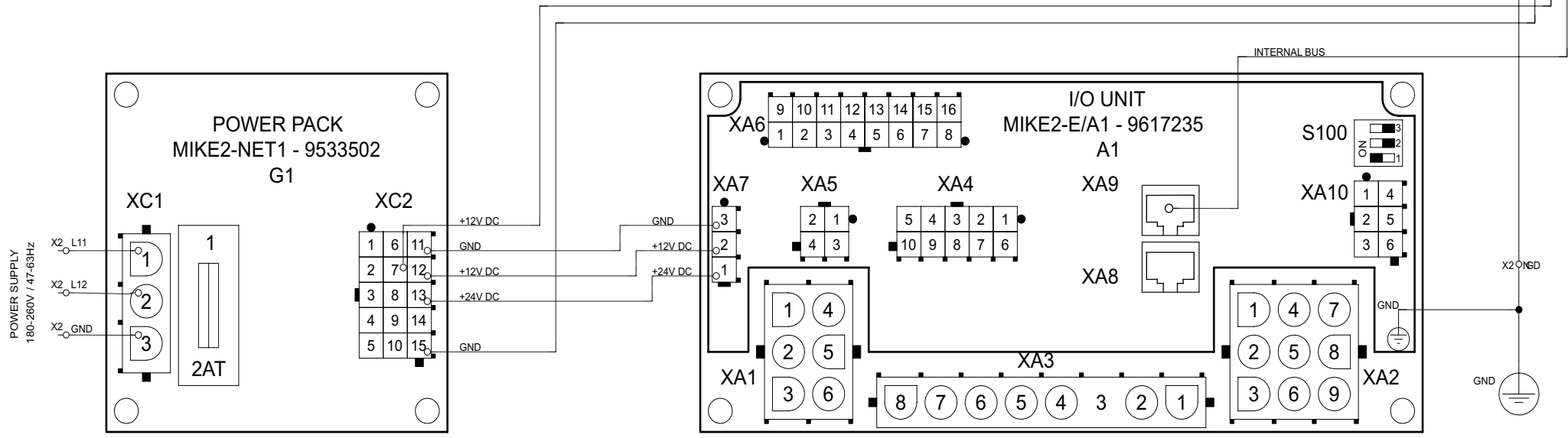

RELEASE FOR PRODUCTION	04/01/2005	LST	
RELEASE ON SUPPLY	04/01/2005	LST	
LAST DRAWER	03/21/2005	LST	
REVISION			

WIRING DIAGRAM



DV120.2T
208V - 230V 3 PH+G 60Hz
ELECTRONIC CONTROL

9643057
DV120.2T
Page 3

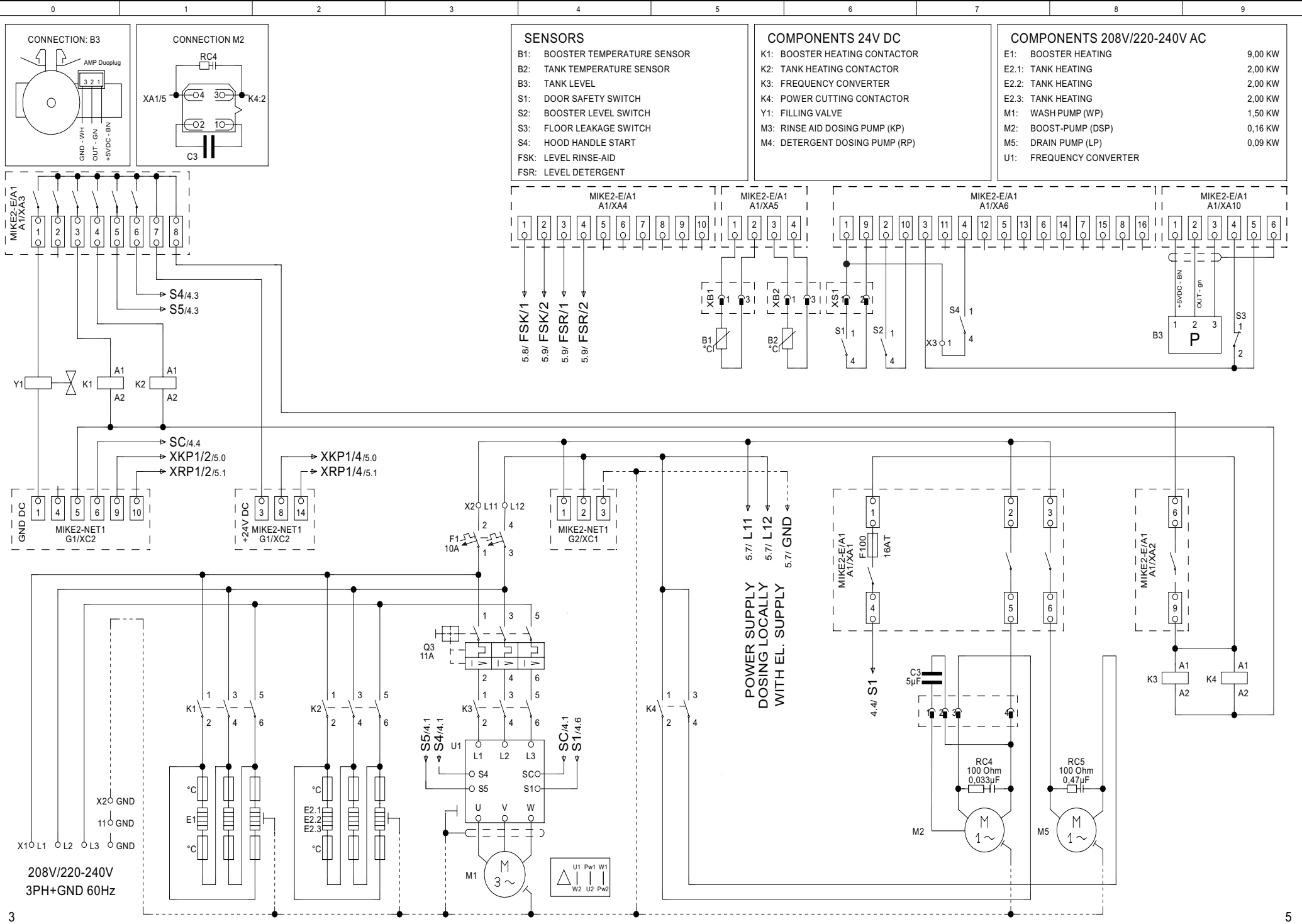

RELEASE FOR PRODUCTION	04/01/2005	LST
RELEASE ON SUPPLY	04/01/2005	LST
LAST DRAWER	03/21/2005	LST
REVISION		

WIRING DIAGRAM

DV120.2T
 208V - 230V 3 PH+G 60Hz
 ELECTRONIC CONTROL

INTERNAL DOSING PUMPS - 24VDC

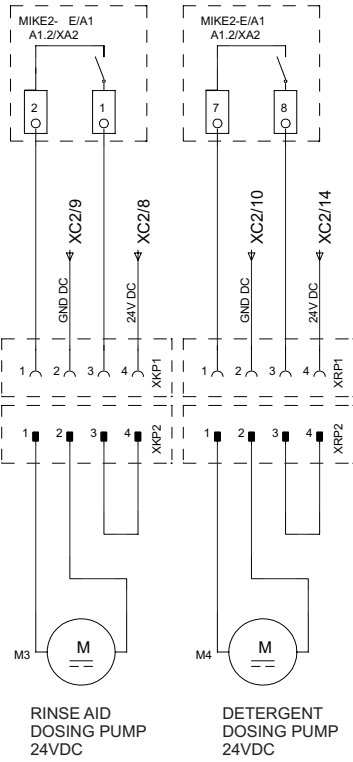

EXTERNAL DOSING PUMPS - LINE VOLTAGE

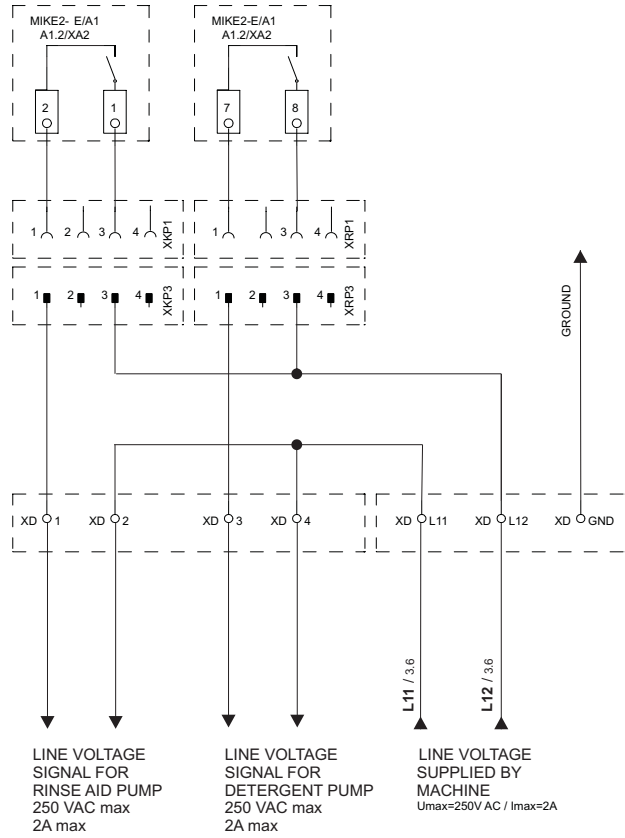

CHEMICAL AGENT LEVEL SENSOR (OPTIONAL)

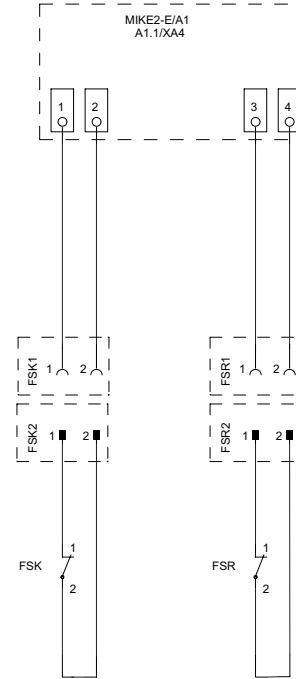

CHEMICAL AGENT LEVEL SENSOR (OPTIONAL)

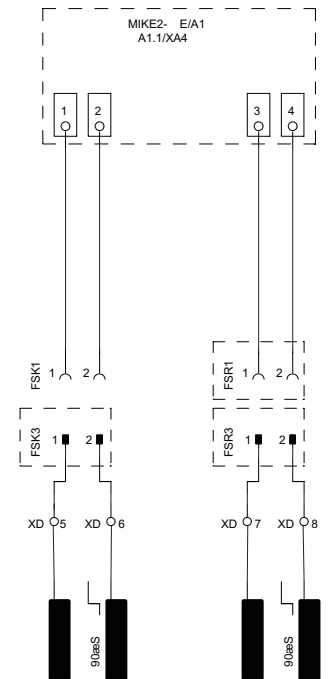

4

RELEASE FOR PRODUCTION	04/01/2005	LST
RELEASE ON SUPPLY	04/01/2005	LST
LAST DRAWER	03/21/2005	LST
REVISION		

WIRING DIAGRAM



DV120.2T
208V - 230V 3 PH+G 60Hz
CHEMICAL DOSING CONNECTIONS

9643057

DV120.2T

EXTERNAL VENT FAN CONTROL

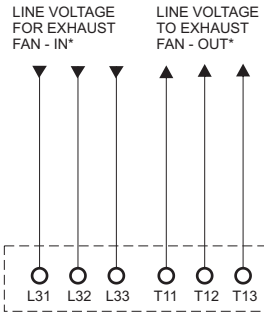
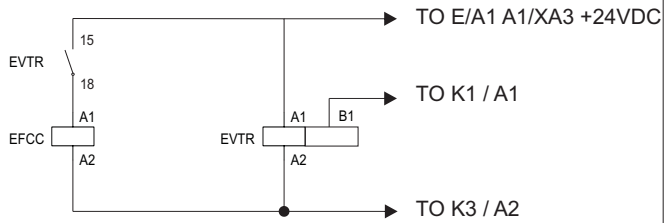

* 12 AWG 20A MAXIMUM

EVTR TIMER SETTINGS - DIAL STYLE

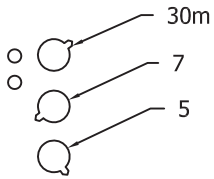

EVTR TIMER SETTINGS - DIP SWITCH STYLE



SET TO 80 %

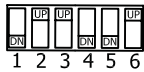

SET DIP SWITCHES TO:

- 1 - DOWN
- 2 - UP
- 3 - UP
- 4 - DOWN
- 5 - DOWN
- 6 - UP

5

RELEASE FOR PRODUCTION	04/01/2005	LST	
RELEASE ON SUPPLY	04/01/2005	LST	
LAST DRAWER	08/16/2010	LST	
REVISION			

WIRING DIAGRAM



DV120.2T
208V - 230V 3 PH+G 60Hz
MACHINE OPTIONS

9643057

DV120.2T