



AZP 80

CLOSE-COUPLED WASTE PULPER

The clean solution

Special Features:

- **Vertically-mounted side grinding system** is less prone to jamming than traditional horizontal bottom-mounted grinders
- **Tungsten carbide cutting blades** for outstanding performance and long life
- **Fully automatic operation**
- **Self-cleaning mode** at machine shutdown
- **Capacity 992 lbs. (450 kg) per hour** of food waste
- **Powerful 8.8 hp grinder motor**
- **Volume reduction of 70-85%**

Standard Features:

- Can process mixed kitchen waste in addition to food waste, including Styrofoam, paper, and cardboard
- Waste is reduced to a nearly dry pulp, with a volume reduction of 70-85%. Water and liquid waste is filtered and drained
- Includes a vertical, side-mounted grinding mechanism and a vertical dewatering press in one unit
- Waste can be loaded using a continuous flushing trough, or manually
- Magnet and catch tray at trough entrance restrict metal cutlery from entering the grinding mechanism
- Door safety switches protect the operator. The unit is shut down automatically if the grinder or dewatering press access doors are opened during operation
- Convenient, reliable electromechanical controls
- Grinding motor is mounted horizontally for easier serviceability



- Vertical dewatering press chamber incorporates self-flushing system to ease cleanup
- Flush-paneled, stainless steel exterior
- Automatic water level control
- Built-in connection points for odor neutralizing pumps

Options:

- Available in left-to-right or right-to-left configurations
- Choice of waste chute locations: front, rear or inline
- Choice of water circulation pumps to accommodate a variety of flushing trough systems
- Separate control panel at remote location
- Flanged, bolt-down feet



AZP 80 Dimensions (left to right)

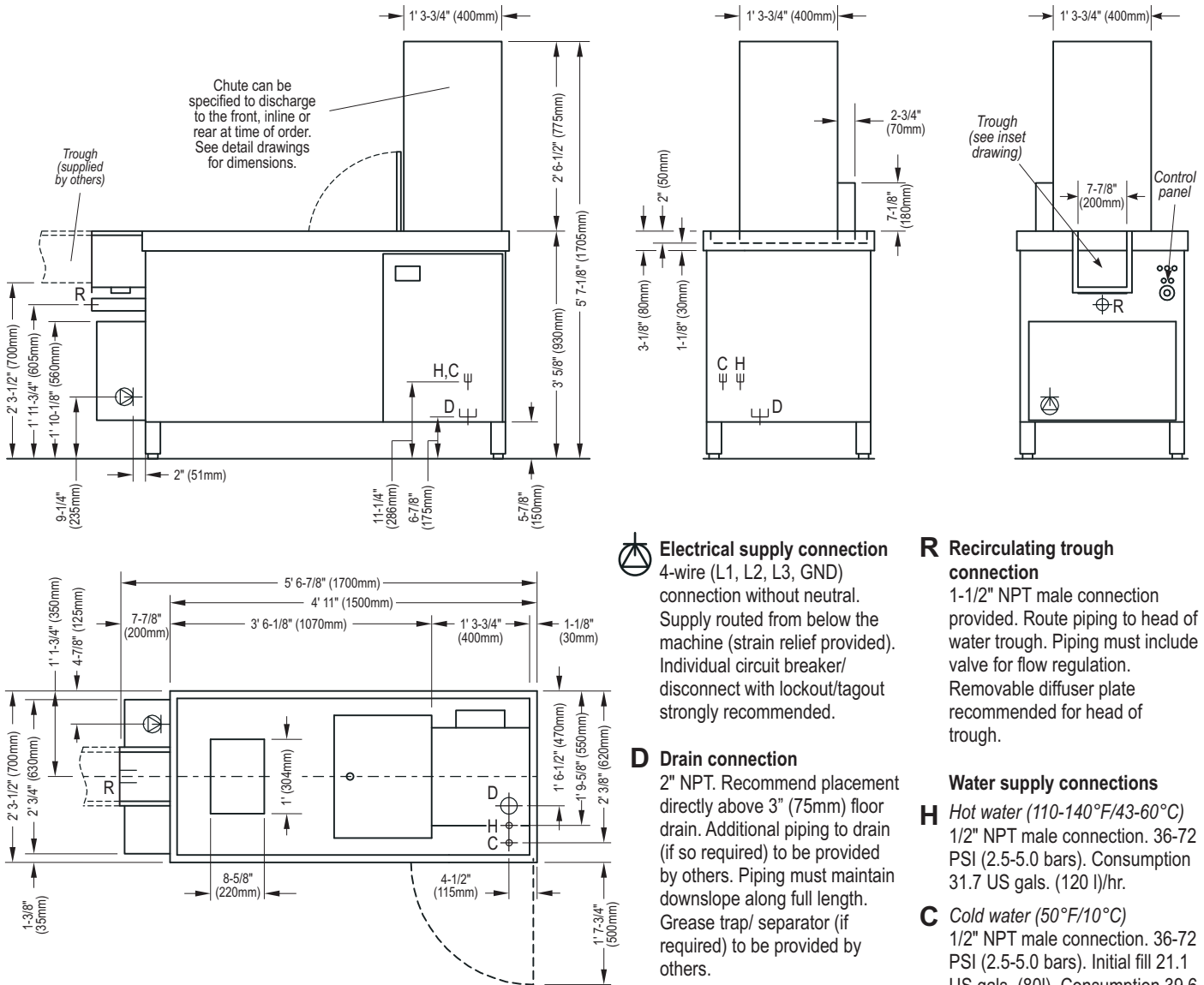

All dimensions from floor +/- 1/2" (13mm) due to adjustable feet.

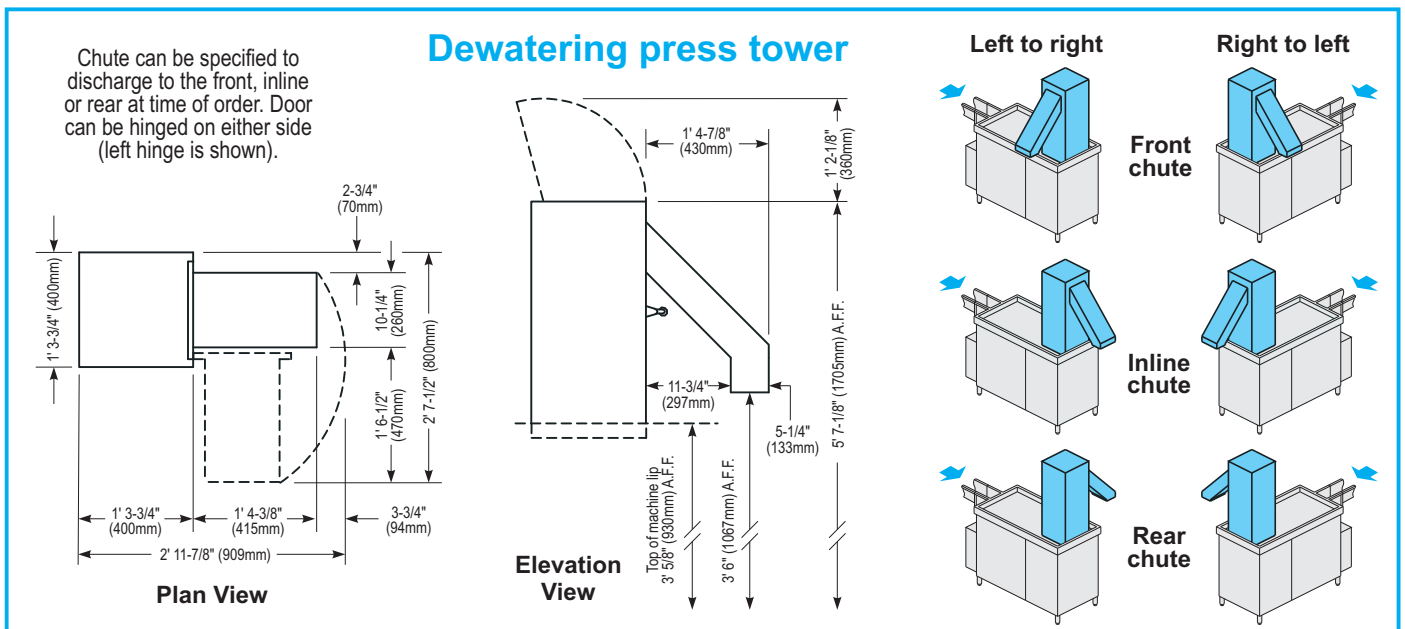

AZP 80 Dimensions (right to left)

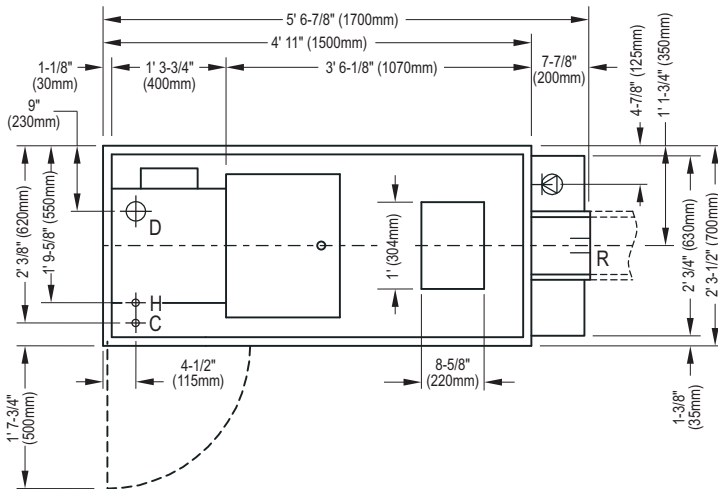
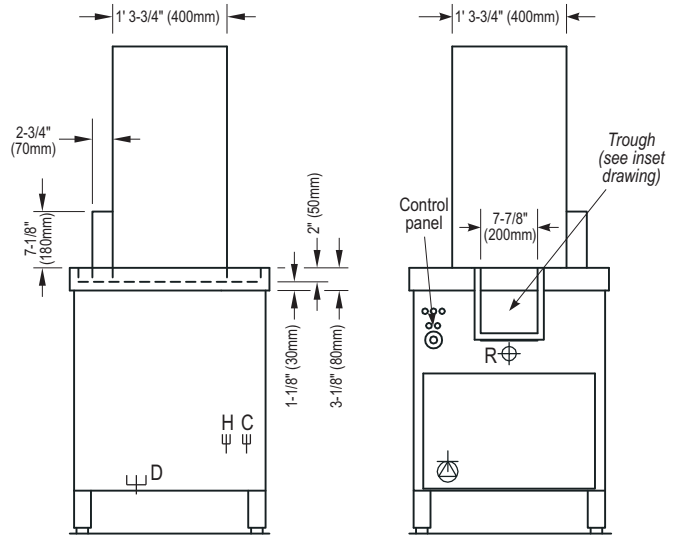
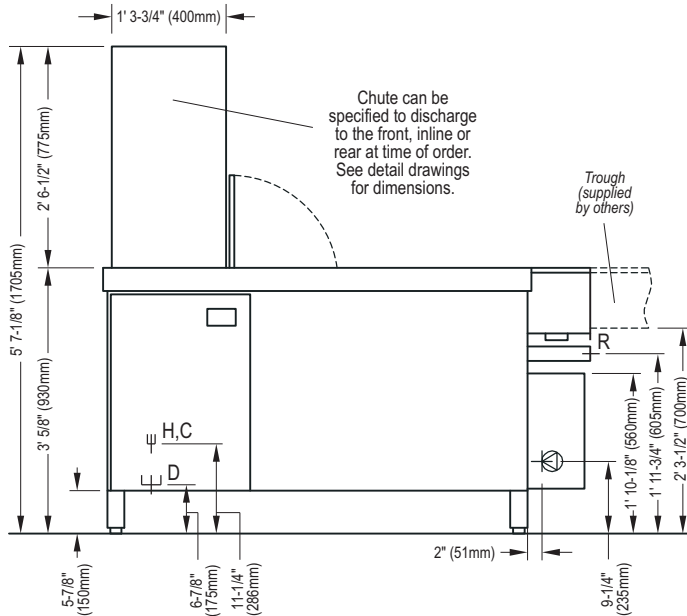

All dimensions from floor +/- 1/2" (13mm) due to adjustable feet.

Recommended trough construction

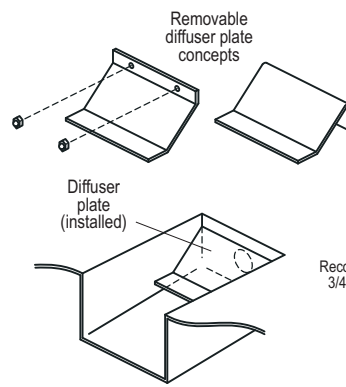

Head of trough should include 45° diffuser plate to distribute water across the entire floor of the trough.

Opening below diffuser plate should be approx 3/4" (20mm) from floor of trough.

Diffuser plate should be removable for cleaning. Exact configuration and fastening of diffuser plate to be determined by table manufacturer in compliance with all applicable code requirements.

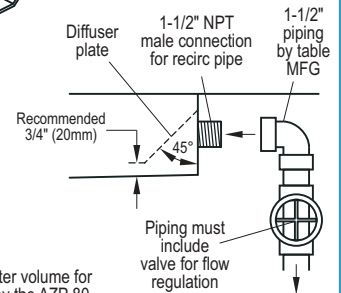

Gusher heads will reduce the available water volume for the trough if they are supplied with water by the AZP 80 recirculation line. For long troughs, MEIKO recommends that any gusher heads be fed by a fresh water supply.

Recommended trough connection

All trough flange holes 0.281" D. 1/4" mounting hardware recommended.

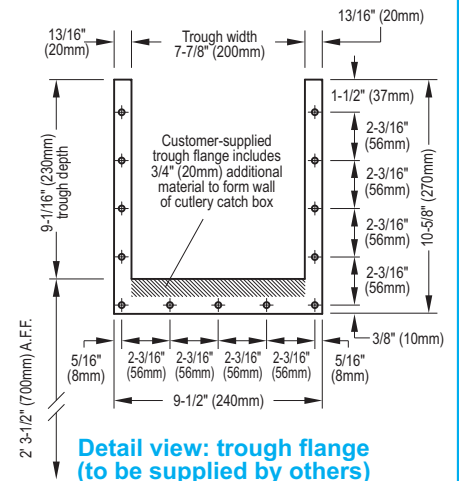
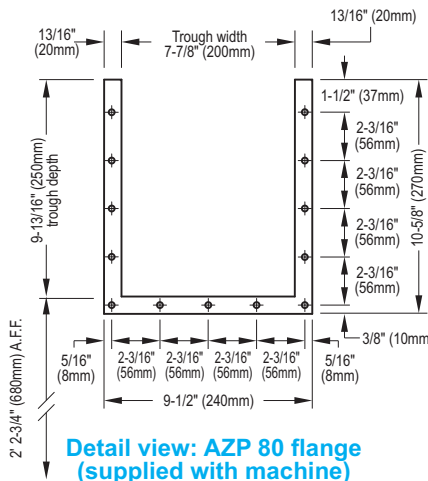
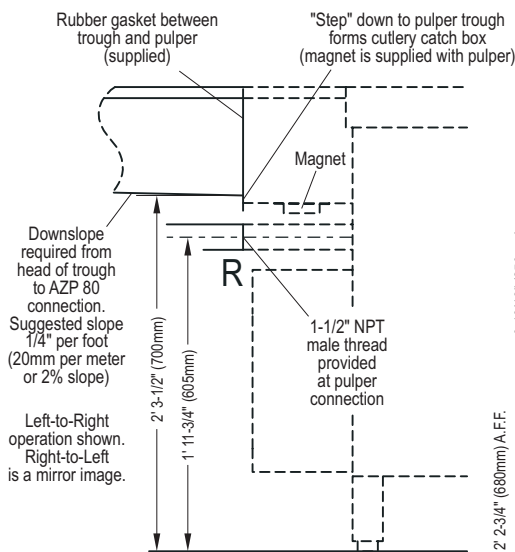

Technical Specifications

Optimum Capacity:

Food waste 992 lbs. (450 kg) per hour
Mixed kitchen waste 705 lbs. (320 kg) per hour

Water Requirements:

Cold water (tank and trough) 1/2" NPT
Temperature 50°F (10°C) recommended
Pressure 36-72 PSI (2.5-5.0 bars)
Initial fill 21.1 gals. (80 liters) plus trough capacity
Consumption 39.6 gals. (150 liters) per hour
Hot water (tower flush) 1/2" NPT
Temperature 140°F (60°) optimum
Pressure 36-72 PSI (2.5-5.0 bars)
Consumption 2.8 gallons (10.5 liters) per hour
7.9 gallons (30 liters) at shutdown
Flow rate 31.7 gals. (120 liters) per hour
Drain 2" NPT
Maximum drain flow rate 38 gals. (143.8 liters) per minute

Electrical Requirements:

Grinder motor 8.8 hp (6.6 kW)
Water press motor 2.0 hp (1.5 kW)

Recirculating pumps:

Troughs up to 20' (6m) in length 1.0 hp (0.75 kW)
Troughs 20-40' (6-12m) in length 2.1 hp (1.6 kW)

Approximate Total Load Amps:

- 208/60/3, 1.0 hp/0.75 kW recirc pump 41.7 A @ 208V
- 208/60/3, 2.1 hp/1.6 kW recirc pump 44.7 A @ 208V
- 230/60/3, 1.0 hp/0.75 kW recirc pump 37.2 A @ 230V
- 230/60/3, 2.1 hp/1.6 kW recirc pump 40.2 A @ 230V
- 460/60/3, 1.0 hp/0.75 kW recirc pump 19.4 A @ 460V
- 460/60/3, 2.1 hp/1.6 kW recirc pump 20.5 A @ 460V

Machine / Shipping Details:

Shipping Weight 1080 lbs. (490 kg)
Shipping Size (W x D x H) 67-14" x 27-1/2" x 81-1/4"
(1708 x 699 x 2064mm)

Some options and accessories may affect shipping weight or dimensions. Contact MEIKO at sales@meiko.us for assistance.

This machine may not pass through standard doorways without machine disassembly or doorway modification. Check all dimensions carefully prior to ordering, or contact MEIKO at sales@meiko.us for assistance.

Water trough connection

The MEIKO AZP 80 includes an integral connection for attachment to a recirculating water trough. If the machine is to be installed without a recirculating water trough, contact MEIKO at sales@meiko.us for additional options and assistance.

Note: All specifications are subject to change without notice based on MEIKO's dedicated product improvement program.

Specification

AZP 80 Item Number _____

Unit will be an NSF and ETL-listed MEIKO AZP 80 waste pulper. Unit will consist of a grinding mechanism and dewatering press in close-coupled formation inside a common housing clad in flush stainless steel panels. Unit will process food waste or mixed kitchen waste to reduce its volume and to convert it to a dry, relatively odorless pulp.

Unit will have a capacity of 992 lbs. (450kg) per hour of food waste, or 705 lbs. (320 kg) per hour of mixed kitchen waste, including Styrofoam, paper and cardboard. Unit will feature waste volume reduction of 70-85% depending on type of waste.

Grinding mechanism will consist of an 8.8 hp (6.6 kW) horizontally-aligned motor driving a vertically-mounted cutting wheel. Grinding mechanism will incorporate tungsten carbide cutters for long-lasting performance. Waste will be fed continually into the grinding mechanism by the flow of water regulated by the machine.

Draining of the ground waste will be accomplished using a vertical screw-type lift and a perforated cylinder, reducing the waste to a dry pulp. The lift and cylinder will incorporate an integral warm-water flushing spray system to minimize cleanup.

Unit will incorporate electro-mechanical controls, as well as features to shut down the unit if the grinder or vertical lift access panels are opened during operation. Unit will feature built-in connection points for odor neutralizing pumps.

Direction of operation will be:

- _____ Left-to-Right
- _____ Right-to-Left

Orientation of waste chute will be:

- _____ Front
- _____ Rear
- _____ Inline

Waste chute door will be hinged on:

- _____ Right side*
- _____ Left side*

* *Standard door swing uses a right-side hinge for machines with inline waste chutes, and hinged to swing the door back towards the machine body for front and rear chutes (to minimize required machine clearance). If desired, a different door swing/hinge location may be specified at time of order.*

Recirculating pump motor will be:

- _____ 1.0 hp (0.75 kW) - for troughs up to 20' (6m) in length
- _____ 2.1 hp (1.5 kW) - for troughs 20-40' (6-12m) in length

Operating voltage will be:

- _____ 208 V / 60 Hz / 3 Ph
- _____ 230 V / 60Hz / 3 Ph
- _____ 460 V / 60 Hz / 3 Ph

Unit will have the following optional features:

- _____ Flanged, bolt-down feet
- _____ Separate wired start/stop switch for installation at a remote location (provide required distance _____)
- _____ In cases where machine is to be installed where a water trough is not present, contact MEIKO at sales@meiko.us for additional options and assistance.