



# K-SERIES INTERNAL BOOSTER HEATER

# RACK CONVEYOR WAREWASHER OPTIONS

- Machine footprint is unchanged - no additional floor space is required for booster heater
- Heater is fully pre-installed and pre-plumbed to greatly simplify installation
- Single-point water connection for machine
- Variable heat output. Heater runs at increased power during machine startup to minimize preheat time, then reduces power during operation to conserve energy while providing a 180°F sanitizing final rinse temperature
- Optimized for Meiko's low water consumption to conserve energy
- Fully enclosed, flush stainless steel paneled exterior with cool-to-the-touch surface
- Available in 40°F and 70°F rise versions



### Technical Specifications

**Electrical Requirements:**

A dedicated booster heater terminal block is located inside the dishwasher's control compartment, adjacent to the main dishwasher terminal block. Information shown here is for the booster heater connection only. For dishwasher electrical requirements, refer to the dishwasher spec sheet.

*70°F rise booster (110°F water supply)*

Rating - Startup and machine fill ..... 28.8 kW  
 Rating - Operation ..... 21.6 kW  
 Approximate Total Load

- 208V/60Hz/3Ph ..... 79.9 A
- 230V/60Hz/3Ph ..... 72.3 A
- 460V/60Hz/3Ph ..... 36.1 A

*40°F rise booster (140°F water supply)*

Rating - Startup and machine fill ..... 14.4 kW  
 Rating - Operation ..... 9.6 kW  
 Approximate Total Load

- 208V/60Hz/3Ph ..... 40.0 A
- 230V/60Hz/3Ph ..... 36.1 A
- 460V/60Hz/3Ph ..... 18.1 A

**Water Requirements**

Incoming water line size ..... 3/4" NPT  
 Incoming water temperature ..... 110°F or 140°F (specify at time of ordering)  
 Incoming water pressure ..... 20 PSI, +/- 5 PSI  
 Incoming water hardness ..... 4-6 grains/gal.  
 Final rinse temperature ..... 180°F

**Dimensions:**

Refer to dishwasher spec sheet. Overall machine dimensions are unchanged by this option.

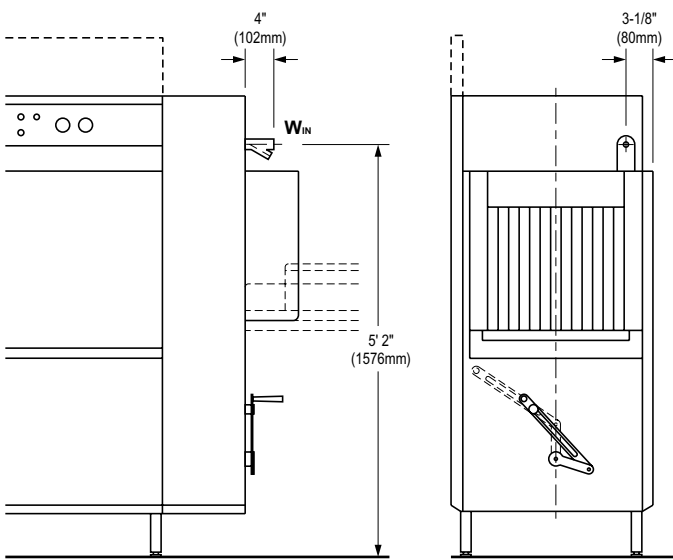

Incoming water supply connection (3/4" NPT)  
 For location of electrical supply connection, refer to the dishwasher spec sheet.

**Note: All specifications are subject to change without notice based on Meiko's dedicated product improvement program.**