



K-90 SERIES

HOT WATER SANITIZING SINGLE-TANK RACK CONVEYOR WAREWASHERS

Exclusive Features:

- **Synchronized side-drive dual rack rail pawl-bar system** ensures complete water coverage from every angle, even the bottom of the rack
- **Large, insulated front doors** are spring-loaded to open easily and STAY open, without latching
- **Computer-positioned wash arms** in easily-removed manifolds. Arms and manifolds are stainless steel, eliminating high-wear gaskets and O-rings
- **Concave, slotted nozzles** minimize clogging. Nozzles are computer-positioned at varying angles to maximize water coverage over all areas of the ware
- **Powerful 3hp pumps** are 50% more powerful than the industry standard for outstanding cleaning
- **Large separation** between wash and rinse (21" upper, 22" lower) avoids splashing of soiled water onto sanitized ware
- **Front-sloping tanks** for complete drainage and easier cleaning
- **External, easily-operated lever drain system** makes draining fast, safe and simple

Standard Features:

- **ENERGY STAR** Qualified
- Capacity **239** racks per hour
- Water consumption **0.43** gallons per rack
- All 304-series stainless steel construction
- Double-wall insulated construction on front, top and back to improve operator safety, conserve heating energy, and reduce noise and heat loss into the dishroom
- Large, easily-removed pan strainers with separate prewash scrap basket
- Fully automatic operation including auto-fill and auto-start. Prewash, wash and final rinse are activated only when a rack is in place to conserve water and detergent
- Powerful 3hp prewash and wash pumps are vertically-mounted to be self-draining and easily removed for servicing
- Electromechanical controls for reliability and easy operation. Low-voltage 24VAC control circuit for operator safety
- Easily accessible detergent and rinse aid injection ports for fast and easy chemical dispenser installation
- Single-point electrical, water and drain connections. Internal booster heater option adds an additional terminal block for simpler replacement of an existing external booster heater
- Low-level heater protection
- Pressure reduction valve (machines without internal booster heater)



Options:

- Choice of two clearance heights (standard 18" or tall hood 26")
- Internal booster heater (steam or electric heat)
- External booster heater (steam or electric heat)
- Master disconnect
- External vent fan control
- Table limit switch
- Vent cowl collars
- Direct drive sideloader
- 90° powered loader or unloaders
- Flanged feet
- Drain water tempering kit
- Shock arrestor
- Pressure reduction valve (machines without internal booster heater)

Models:

- K-90E: 18" vertical clearance, electric heat
- K-90S: 18" vertical clearance, steam coil heat
- K-90ET: 26" vertical clearance, electric heat
- K-90ST: 26" vertical clearance, steam coil heat



K-90 Series, left-to-right - electric heat w/o internal booster *OR* steam heat (all)

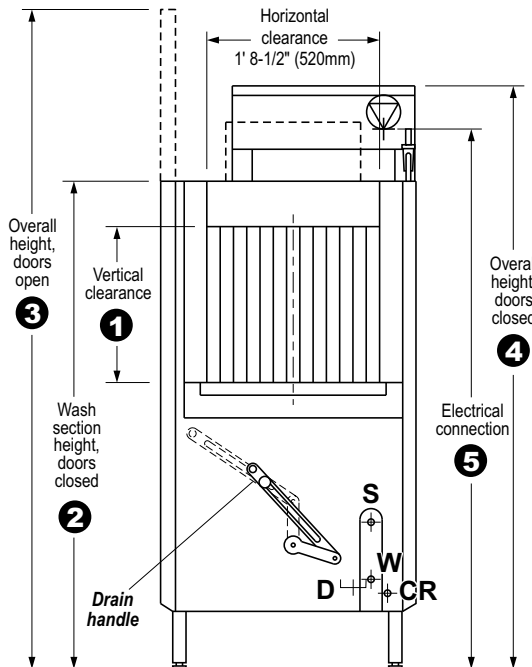
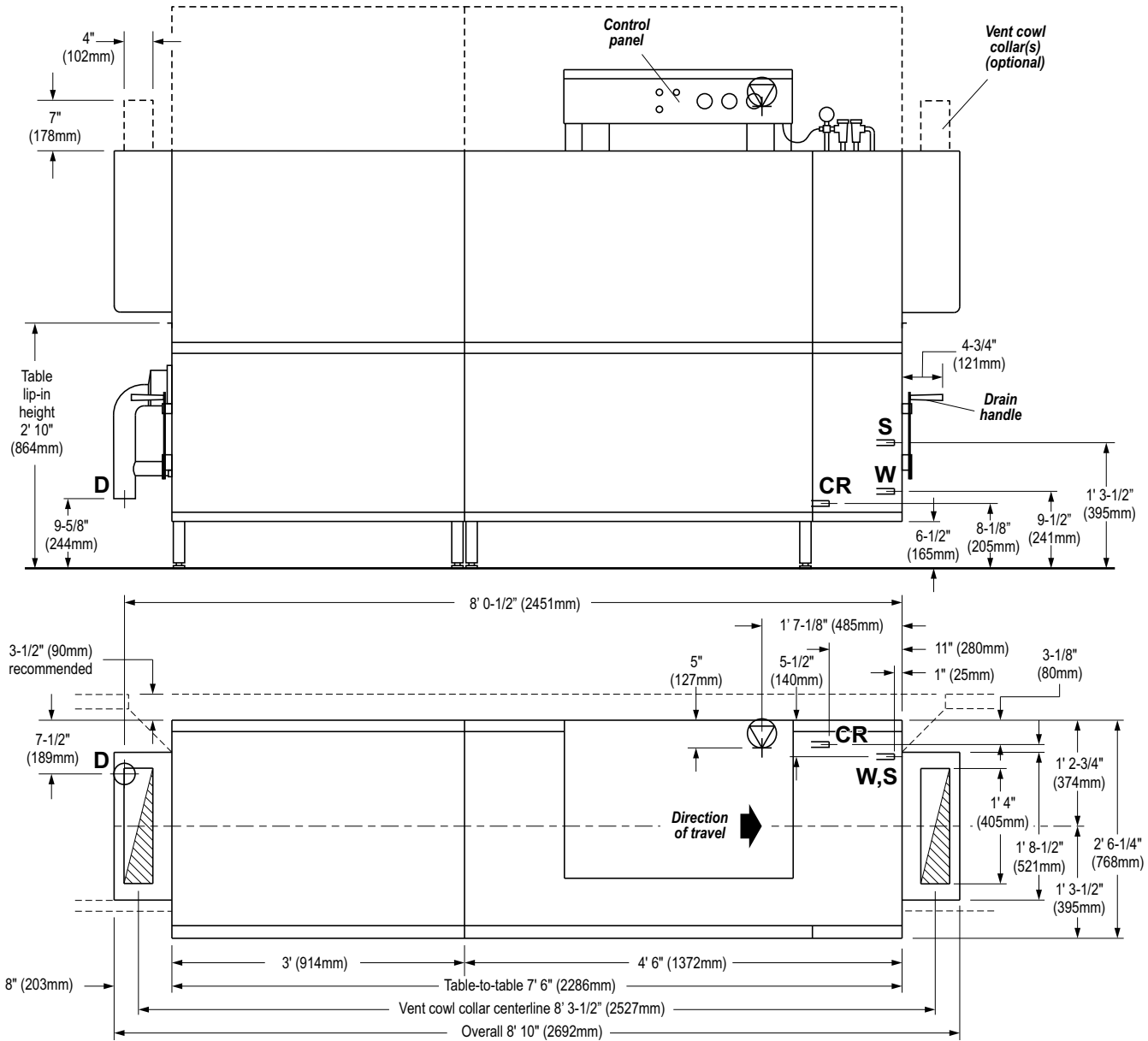

Variable Dimensions

All dimensions from floor are +/- 1/2" due to adjustable feet.

	Standard height machines	Tall hood machines
①	1' 6" (457mm)	2' 2" (660mm)
②	4' 9-7/8" (1471mm)	5' 5-7/8" (1673mm)
③	6' 7-7/8" (2030mm)	7' 11-7/8" (2435mm)
④	5' 9-1/8" (1756mm)	6' 5-1/8" (2435mm)
⑤	5' 4" (1626mm)	6' (1829mm)

Utility Connection Symbols

Utility ratings and connection specifications on Page 6.

D	Drain	W	Water
	Electrical	S	Steam
	Ventilation	CR	Condensate return

K-90 Series, right-to-left - electric heat w/o internal booster *OR* steam heat (all)

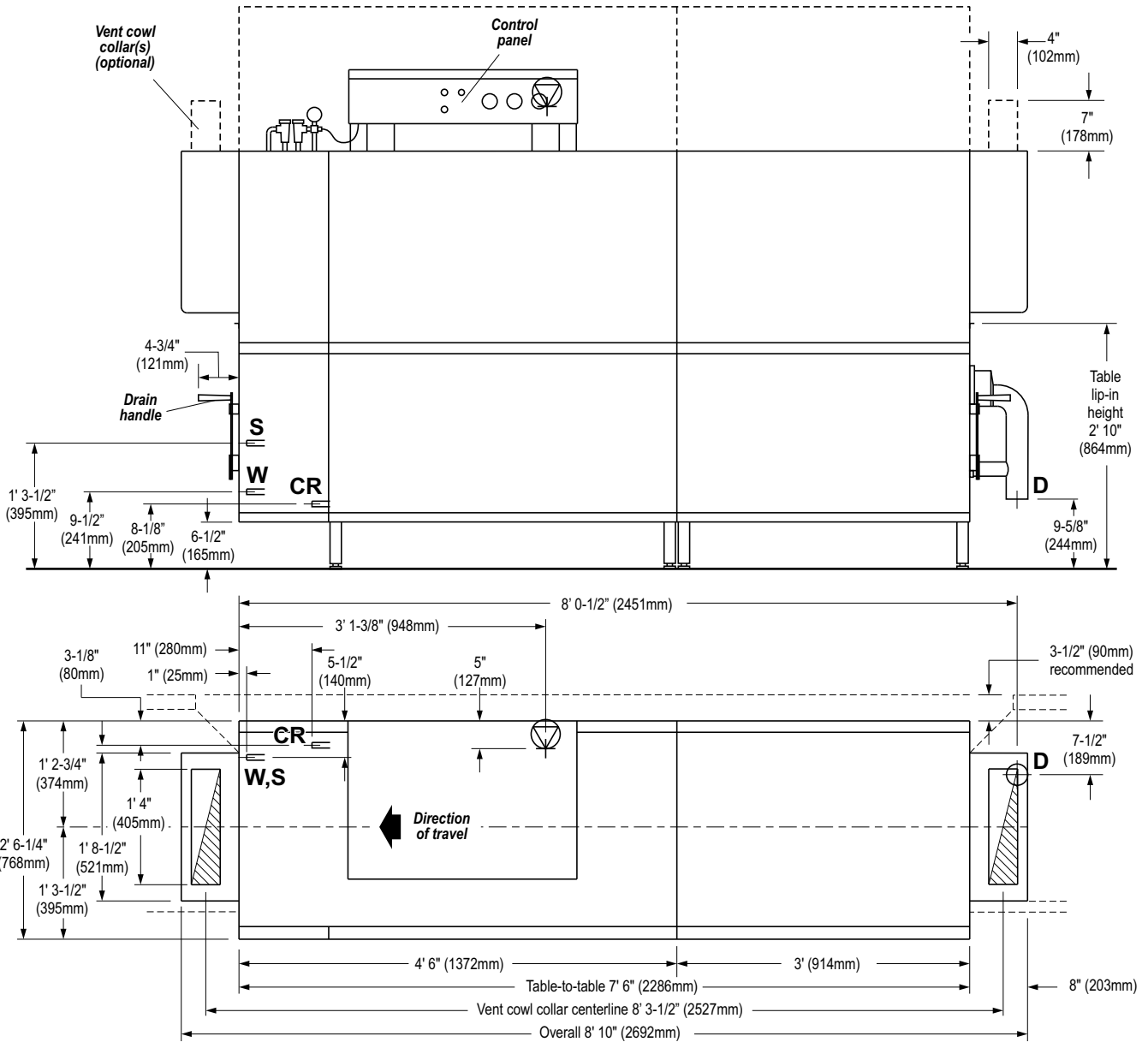

Variable Dimensions

All dimensions from floor are +/- 1/2" due to adjustable feet.

	Standard height machines	Tall hood machines
①	1' 6" (457mm)	2' 2" (660mm)
②	4' 9-7/8" (1471mm)	5' 5-7/8" (1673mm)
③	6' 7-7/8" (2030mm)	7' 11-7/8" (2435mm)
④	5' 9-1/8" (1756mm)	6' 5-1/8" (2435mm)
⑤	5' 4" (1626mm)	6' (1829mm)

Utility Connection Symbols

Utility ratings and connection specifications on Page 6.

- D** Drain
- W** Water
-  Electrical
- S** Steam
-  Ventilation
- CR** Condensate return

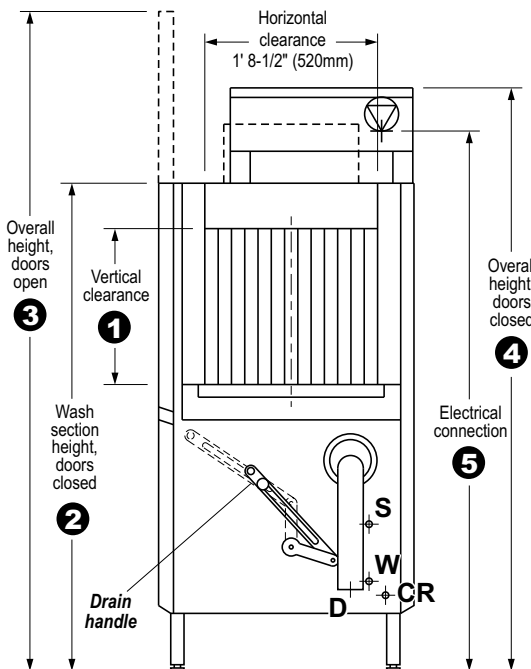

K-90 Series, left-to-right - electric heat with internal booster

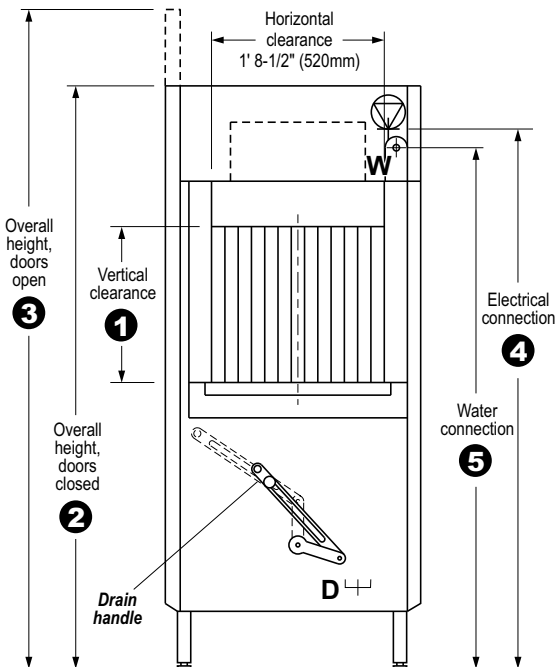
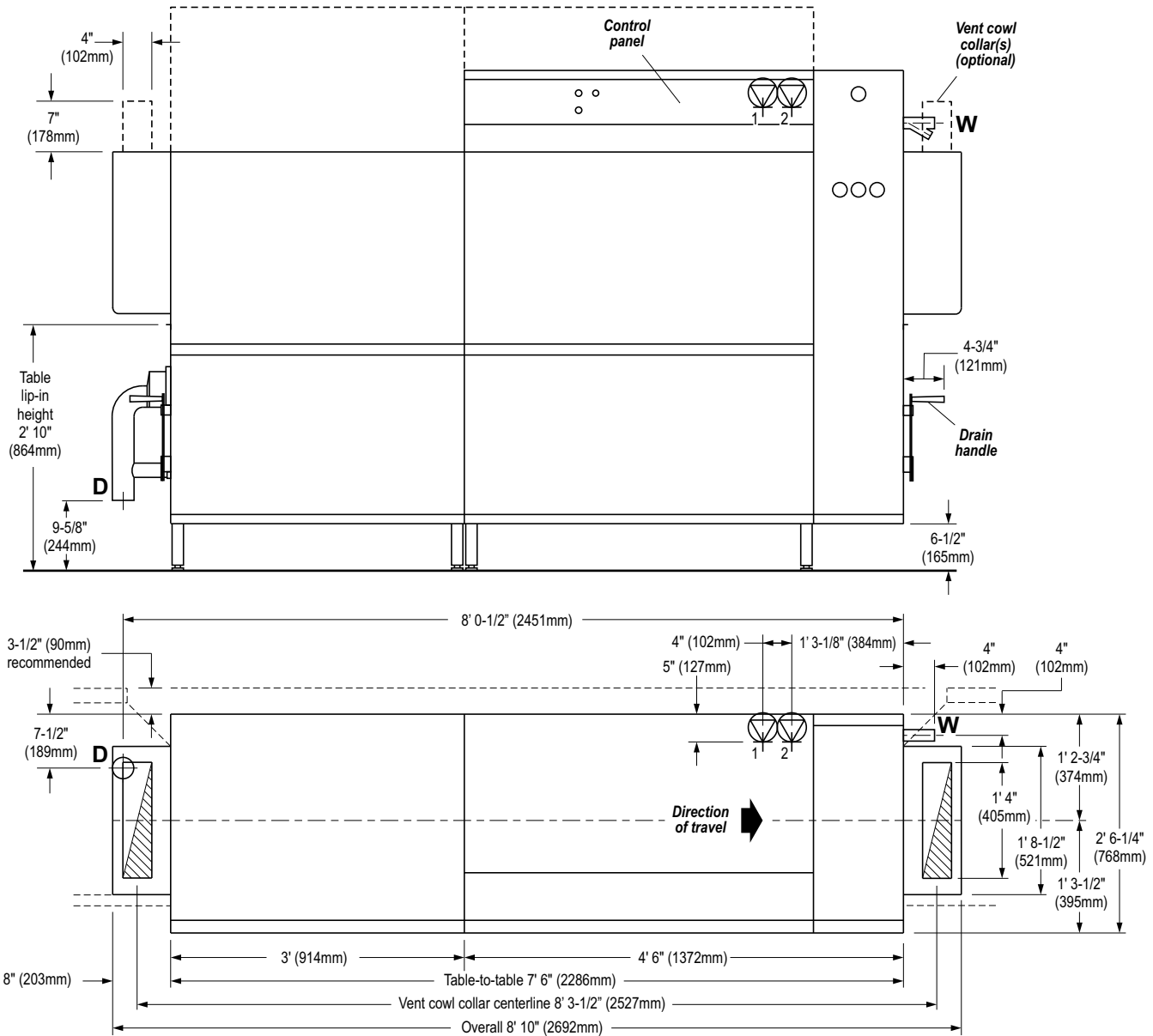

Variable Dimensions

All dimensions from floor are +/- 1/2" due to adjustable feet.

	Standard height machines	Tall hood machines
①	1' 6" (457mm)	2' 2" (660mm)
②	5' 9-1/8" (1756mm)	6' 5-1/8" (2435mm)
③	6' 7-7/8" (2030mm)	7' 11-7/8" (2435mm)
④	5' 4" (1626mm)	6' (1829mm)
⑤	5' 2" (1576mm)	5' 10" (1778mm)

Utility Connection Symbols

Utility ratings and connection specifications on Page 6.

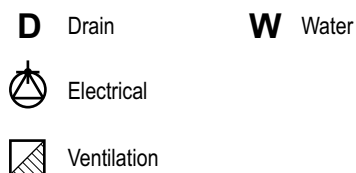

K-90 Series, right-to-left - electric heat with internal booster

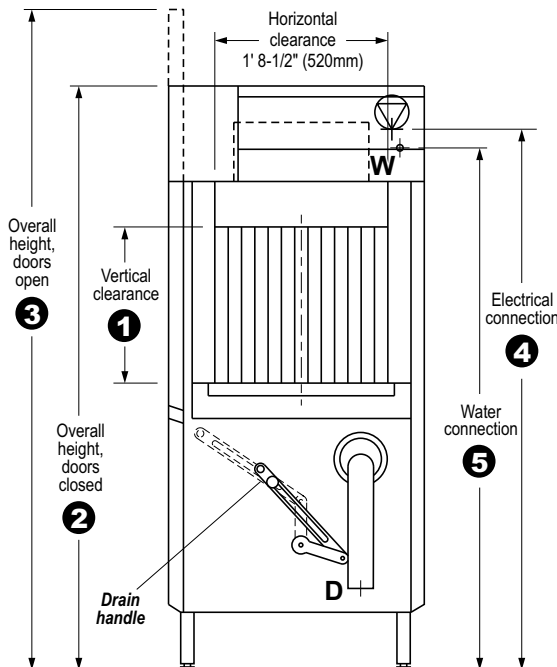
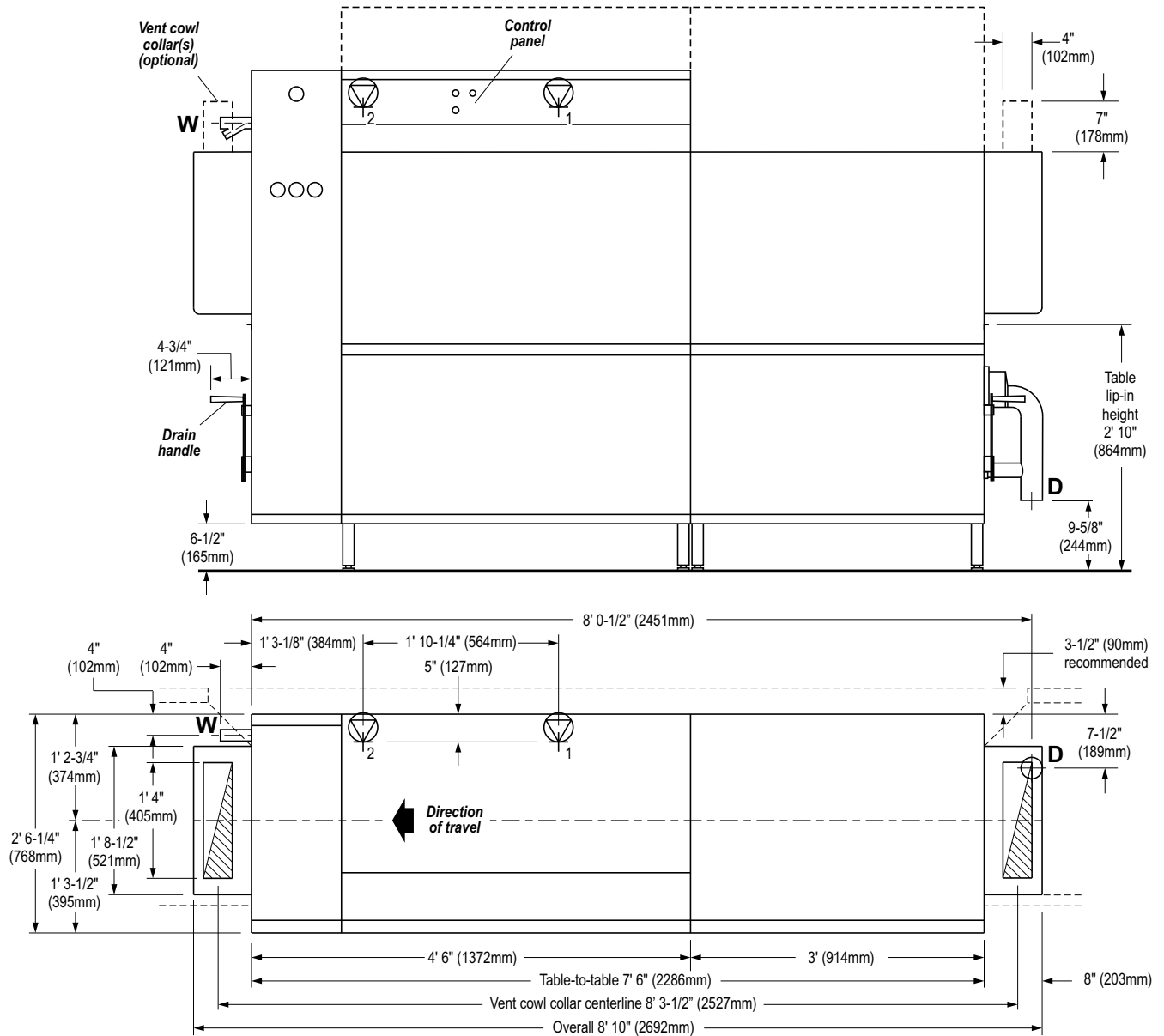

Variable Dimensions

All dimensions from floor are +/- 1/2" due to adjustable feet.

	Standard height machines	Tall hood machines
①	1' 6" (457mm)	2' 2" (660mm)
②	5' 9-1/8" (1756mm)	6' 5-1/8" (2435mm)
③	6' 7-7/8" (2030mm)	7' 11-7/8" (2435mm)
④	5' 4" (1626mm)	6' (1829mm)
⑤	5' 2" (1576mm)	5' 10" (1778mm)

Utility Connection Symbols

Utility ratings and connection specifications on Page 6.

- D** Drain
- W** Water
- Electrical
- Ventilation

K-90 Series Utility Connections

D Drain

2-15/16" (75mm) OD vertical, gravity-fed drain outlet (HDPE piping). Recommend placement directly above 4" floor drain. Additional piping to drain (if so required) to be supplied by customer.

Connection is 9-5/8" (244mm) AFF. If using optional 2" NPT adapter, connection is 8-1/2" (214mm) AFF. Refer to **Detail View: Drain** for suggested connection.



Single electrical connection

- Single terminal block inside control box (4-wire with ground - no neutral).

Dual electrical connections - machines with internal electric booster heater

- Two terminal blocks inside control box (4-wire with ground - no neutral).

- Machine electrical supply
- Booster heater electrical supply

Electrical supply (or supplies) should be routed into control box through strain relief(s) on rear of control box. Incoming leads must be appropriately sized for electrical supply. Individual disconnect with lockout/tagout strongly recommended (provided by customer).

Connection for standard-height machines is 5' 4" (1626mm) AFF. Connection for tall hood machines is 6' (1829mm) AFF.

Refer to utility chart on Page 7 for electrical load information.



Vent connection - machines with optional vent cowl collars

Refer to **Detail View: Vent** for suggested connection.

The waste air connection must be corrosion-resistant and frost-free. In particular, provisions must be made to prevent air temperatures of 32°F/0°C or colder from reaching the machine at any time. A provision for draining moisture from the waste air pipe is strongly recommended.

- Load end - 200 CFM
- Unload end - 350 CFM
- Total - 550 CFM

W Hot water connection - machines without internal booster heater

1/2" NPT female pipe connection is 9-1/2" (241mm) AFF.

- Temperature 180°F (82°C)
- Pressure 15-25 PSI
- Initial fill 61.6 U.S. gals. (233.2 liters)
- Consumption 102.0 U.S. gals per hour (386.1 liters) per hour
- Recommended hardness 1-6 grains/U.S. gal.

W Water connection - machines with internal booster heater only

For steam heat, 1/2" NPT female pipe connection is 9-1/2" (241mm) AFF. For electric heat, 1/2" NPT female pipe connection is 5' 2" (1576mm) AFF for standard-height, 5' 10" (1778mm) AFF with tall hood option.

- Temperature:
 - Machines with 40°F booster: 140°F (60°C)
 - Machines with 70°F booster: 110°F (43°C)
- Pressure 15-25 PSI
- Initial fill 61.6 U.S. gals. (233.2 liters)
- Consumption 102.0 U.S. gals per hour (386.1 liters) per hour
- Recommended hardness 1-6 grains/U.S. gal.

S Steam connection - steam-heated machines

3/4" NPT male pipe connection is 1' 3-1/2" (395mm) AFF.

- Pressure 10-30 PSI. Consult factory if steam pressure is below 10 PSI. If pressure is above 30 PSI, use of a regulator is REQUIRED (supplied by customer).
- Consumption: Refer to utility chart on Page 7

CR Condensate return connection - steam-heated machines

3/4" NPT male pipe connection is 8-1/8" (205mm) AFF. Condensate line MUST be pressure-free.

DETAIL VIEW: VENT

Machines equipped with optional vent cowl collars may be installed underneath a ventilation hood, or may use "pant leg" ventilation ducts (to be supplied by the customer). To determine the dimensions of the duct, first determine how they will be installed:

- Duct sleeved outside collar**
Inside dimensions of duct: 4" W x 16" D (102 x 406mm).
- Duct sleeved inside collar**
Outside dimensions of duct: 3-3/4" W x 15-3/4" D (95 x 400mm).

The duct must not interfere with the adjustable baffle, as shown.

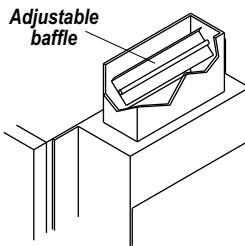

Duct sleeved outside collar (recommended)

4" x 16" (102x406mm)
inside dimensions

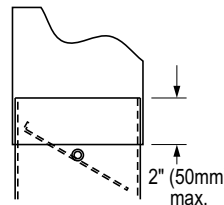

Duct sleeved inside collar (if required)

3-3/4" x 15-3/4" (95x400mm)
outside dimensions

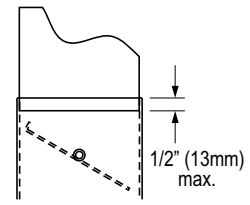

DETAIL VIEW: DRAIN

The machine is equipped with a 2-15/16" (75mm) OD vertical, gravity-fed drain. If possible, the machine drain can simply be positioned directly above a 4" floor drain.

If a floor drain is not in the correct location, or if local codes require a trap, a 2" indirect drain line may be attached using the supplied 2" NPT male adapter.

Choose a piping material that:

- Complies with any applicable local and national codes
- Is rated for use with water temperatures up to 180°F/82°C
- Is rated for 3-12 pH to accommodate detergents and rinse aid in the drain water

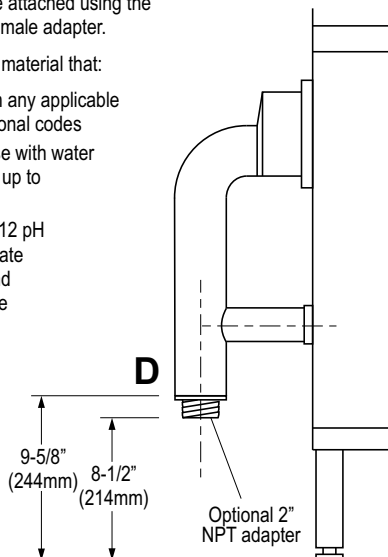

DETAIL VIEW: TABLING

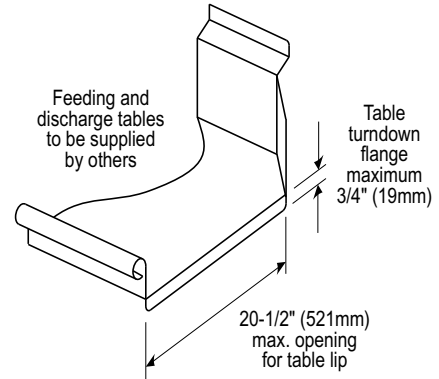
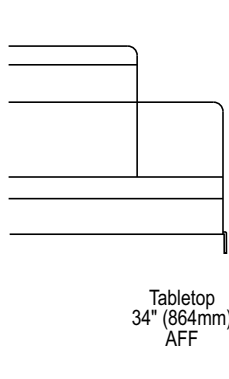

Outside view

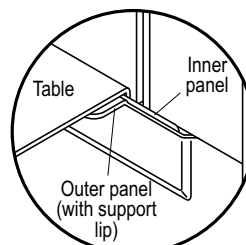

Inside view

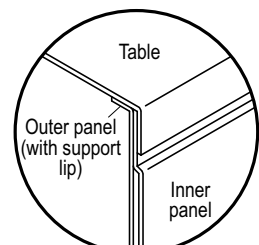

Check that the table lip overlaps BOTH the inner and outer panels.

Use silicone sealer between the table lip and the machine to prevent leakage.

K-90 Series Technical Specifications

Operating Capacities (NSF Rated)

Racks per hour	239
Dishes per hour	5,975
Glasses per hour	8,604

Conveyor Specifications

Conveyor belt speed	6.64 feet/min. (2.02m/min.)
Horizontal clearance	1' 8-1/2" (520mm)
Vertical clearance (K-90E, K-90S)	1' 6" (457mm)
Vertical clearance (K-90ET, K-90ST)	2' 2" (660mm)

Venting Specifications

Load end	200 CFM (336m ³ /h)
Unload end	350 CFM (588m ³ /h)
Total	550 CFM (924m ³ /h)

Shipping Information

K-90E, K-90S:	
Machine weight	886 lbs. (402kg)
Shipping weight	987 lbs. (448kg)
Crating (LxWxH)	9' 5" x 3' x 6' 3" (2.9 x 0.9 x 1.9m)
	176.6 cu. ft. (4.9m ³)
K-90ET, K-90ST:	
Machine weight	996 lbs. (452kg)
Shipping weight	1,097 lbs. (498kg)
Crating (LxWxH)	9' 5" x 3' x 6' 11" (2.9 x 0.9 x 2.1m)
	195.4 cu. ft. (5.5m ³)

Water Specifications

Minimum water temperatures:	
Prewash tank	110-140°F (43-60°C)
Wash tank	160°F (72°C)
Final rinse	180°F (82°C)
Minimum incoming water temperature:	
Machines without internal booster	180°F (82°C)
Machines with internal booster	110° or 140°F (43° or 60°C)
Initial fill	61.6 U.S. gals. (233.2 liters)
Prewash tank capacity	28.5 U.S. gals. (107.9 liters)
Wash tank capacity	33.1 U.S. gals. (125.3 liters)

Incoming water line size	1/2" NPT
Recommended water hardness	1-6 grains/U.S. gal.
Consumption at 100% capacity:	102.0 U.S. gals. (386.1 liters)/hr.
	0.43 U.S. gals. (1.62 liters)/rack
Final rinse flow pressure	15-25 PSI (1.0-1.7 bars)
Flow rate	1.70 U.S. gals. (6.44 liters)/min.

Electrical Specifications

Machine supply connection	Peak current draw	Minimum supply circuit ampacity	Maximum breaker/disconnect	Internal booster heater supply connection	Rating, machine startup	Rating, machine operation	Peak current draw	Minimum supply circuit ampacity	Maximum breaker/disconnect
K-90E (standard height, electric tank heat)				40°F rise electric booster (140°F/60°C water supply temperature)					
208V/60 Hz/3 Ph	60.4 A	80 A	80 A	208V/60 Hz/3 Ph	14.4 kW	9.6 kW	40.0 A	50 A	50 A
230V/60 Hz/3 Ph	55.2 A	70 A	70 A	230V/60 Hz/3 Ph	14.4 kW	9.6 kW	36.1 A	50 A	50 A
460V/60 Hz/3 Ph	27.0 A	35 A	35 A	460V/60 Hz/3 Ph	14.4 kW	9.6 kW	18.1 A	25 A	25 A
K-90ET (tall hood, electric tank heat)				70°F rise electric booster (110°F/43°C water supply temperature)					
208V/60 Hz/3 Ph	72.7 A	100 A	100 A	208V/60 Hz/3 Ph	28.8 kW	21.6 kW	79.9 A	100 A	100 A
230V/60 Hz/3 Ph	63.9 A	80 A	80 A	230V/60 Hz/3 Ph	28.8 kW	21.6 kW	72.3 A	100 A	100 A
460V/60 Hz/3 Ph	30.8 A	40 A	40 A	460V/60 Hz/3 Ph	28.8 kW	21.6 kW	36.1 A	50 A	50 A
K-90S, K-90ST (standard height and tall hood, steam coil tank heat)				Electric tank heater ratings (K-80E, K-80ET)					
208V/60 Hz/3 Ph	18.7 A	25 A	25 A		208V/60Hz/3Ph	230V/60Hz/3Ph	460V/60Hz/3Ph		
230V/60 Hz/3 Ph	18.7 A	25 A	25 A	K-90E	15.0 kW	14.6 kW	15.0 kW		
460V/60 Hz/3 Ph	8.2 A	15 A	15 A	K-90ET	19.5 kW	18.0 kW	18.0 kW		
				Prewash pump motor					3.0 hp
				Wash pump motor					3.0 hp
				Conveyor motor					0.125 hp

Steam Specifications (K-90S, K-90ST)

Steam line connection	3/4" NPT
Condensate return connection	3/4" NPT
Steam pressure	10-30 psi (0.7-2.0 bars)
Consumption:	60 lbs./hr.
Internal Steam Booster Heater:	
40°F rise steam booster (140°F/60°C water supply temperature)	50 lbs./hr.
70°F rise steam booster (110°F/43°C water supply temperature)	100 lbs./hr.

External Booster Heater Recommendations (for machines without optional internal booster heater)

Booster ratings are based on peak capacity of 102.0 U.S. gals./hr. and a flow rate of 1.7 U.S. gals./min. Recommended boosters are one size larger than required to help compensate for any local conditions that may prevent full performance.

Water supply temperature	Required temperature rise	Recommended booster rating
110°F/43°C	70°F/39°C	24 kW
140°F/60°C	40°F/22°C	12 kW

Note: All specifications are subject to change without notice based on MEIKO's dedicated product improvement program.

Equipment Specification: K-90 Rack Conveyor Warewasher - Item No. _____

Item will be a **MEIKO K-90** single tank, rack conveyor dishmachine, consisting of a prewash zone with a 3 hp pump motor, a wash zone with a 3 hp pump motor, and a final rinse zone. Total length of the tank section (not including vent cowls) will be 7' 6" (2286mm). Unit will utilize a 180°F/82°C minimum fresh water sanitizing rinse.

Unit will have a capacity of 239 racks per hour at an NSF-rated belt speed of 6.64 feet (2.02m) per minute. Unit will consume an NSF-rated 102.0 U.S. gals./386.1 liters per hour (0.43 U.S. gals./1.62 liters per rack).

The dishmachine will be NSF, UL and CUL listed.

Electrical characteristics:

- 208V/60 Hz/3 Ph
- 230V/60 Hz/3 Ph
- 460V/60 Hz/3 Ph

Wash tank temperature will be maintained at a minimum of 160°F/72°C. Tank heating will be accomplished by:

- Thermostatically-controlled electric heating elements (K-90E, K-90ET)
- Thermostatically-controlled stainless steel steam coils (K-90S, K-90ST)

Direction of conveyor travel will be:

- Right-to-Left
- Left-to-Right

Unit will have the following standard features:

- Double-wall, insulated construction on top, front, and rear.
- Five upper prewash arms and four lower prewash arms.
- Five upper wash arms with 19" (483mm) wash area and five lower wash arms with 18" (457mm) wash area.
- Wash arm spray pattern ensures effective coverage with varying angles and offset spray jets. Slotted, concave wash nozzles and captivated end caps for easier cleaning.
- Minimum separation between wash and final rinse of 21" (533mm) upper and 22" (559mm) lower.
- Exclusive synchronized rack rail pawl bar system for smooth rack movement. Side drive system provides easy cleaning access and eliminates wash pattern obstruction.
- Front-sloping tanks for complete tank drainage, accessibility, and cleanability.
- Fully automatic operation including auto-fill and auto-start.
- Separate compartment actuator switches to ensure prewash, wash and final rinse are energized only when a rack is in place.
- External, easily operable, lever-operated drain system.
- Low level heater protection.
- Prewash and wash pump motors are self-draining, internal and vertically installed for easy access and serviceability.
- Prewash and wash pump housing and impeller constructed of stainless steel.
- Electromechanical controls with a 24 VAC control circuit.
- Single point electrical connection.
- Easily removable prewash and wash arm block manifold systems, and final rinse arms.
- Large front access doors can be opened with one hand and remain open without latches, aiding machine accessibility and cleanability.
- Large, removable stainless pan strainers with separate prewash scrap basket.
- Single point drain connection.
- Pressure reduction valve (machines with internal booster heater only).

Unit will have the following optional features (check all that apply):

- | | |
|---|--|
| <input type="checkbox"/> Tall hood option to increase vertical clearance from 1' 6" (457mm) to 2' 2" (660mm) | <input type="checkbox"/> Table limit switch |
| <input type="checkbox"/> Internal booster heater (steam or electric per machine spec). Electrically-heated internal booster heater adds 1 electrical terminal block to machine (2 total). | <input type="checkbox"/> Inline (whisker switch) style |
| <input type="checkbox"/> Sized for a minimum 40°F (22°C) rise and 140°F (60°C) min. incoming water temperature | <input type="checkbox"/> End stop style |
| <input type="checkbox"/> Sized for a minimum 70°F (39°C) rise and 110°F (43°C) min. incoming water temperature | <input type="checkbox"/> Vent cowl collar(s) with adjustable damper
4" W x 16" D x 7" H (102x406x178mm) |
| <input type="checkbox"/> External booster heater | <input type="checkbox"/> At both ends |
| <input type="checkbox"/> Sized for a minimum 40°F (22°C) rise and 140°F (60°C) min. incoming water temperature | <input type="checkbox"/> At load end only |
| <input type="checkbox"/> Sized for a minimum 70°F (39°C) rise and 110°F (43°C) min. incoming water temperature | <input type="checkbox"/> At unload end only |
| <input type="checkbox"/> Steam heated | <input type="checkbox"/> 90° side loader (unhooded), 23" long |
| <input type="checkbox"/> Electrically heated | <input type="checkbox"/> 90° side loader (hooded), 23" long |
| <input type="checkbox"/> Master disconnect | <input type="checkbox"/> 90° power loader, 34-1/4" long |
| <input type="checkbox"/> External vent fan control | <input type="checkbox"/> 90° power unloader, 34-1/4" long |
| | <input type="checkbox"/> Flanged feet for permanent installation |
| | <input type="checkbox"/> Drain water tempering kit |
| | <input type="checkbox"/> Shock arrestor |
| | <input type="checkbox"/> Pressure reduction valve (machines without internal booster heater only) |