



## K-76 SERIES

### HOT WATER SANITIZING SINGLE-TANK RACK CONVEYOR WAREWASHERS

Meiko's K-76 rack conveyor warewasher combines state-of-the-art advanced features with economical and reliable operation. A powerful 3 HP wash pump, combined with computer-positioned wash arms with varying spray angles and offset jets, ensures outstanding water coverage and consistent cleaning. Wash arms are pre-assembled into easily-removed manifolds, and feature slotted, concave nozzles (which minimize clogging) and captivated end caps (which can't be lost during cleaning).

Other standard features include fully automatic operation, double-wall insulated construction, a unique external lever-operated drain system, low voltage control circuit, and standard vent cowls with double curtains to reduce splash-out. As with all products synonymous with the name "Meiko," engineering excellence, manufacturing quality and performance come to the forefront in the K-Series rack conveyors.



#### Exclusive Features:

- **Synchronized side-drive dual rack rail pawl-bar system** ensures complete water coverage from every angle, even the bottom of the rack
- **Large, insulated front doors** are spring-loaded to open easily and STAY open, without latching
- **Computer-positioned wash arms** in easily-removed manifolds. Manifolds are stainless steel with a unique interlock system to eliminate high-wear O-rings
- **Concave, slotted nozzles** minimize clogging. Nozzles are computer-positioned at varying angles to maximize water coverage over all areas of the ware
- **Powerful 3hp wash pump** is 50% more powerful than the industry standard for outstanding cleaning
- **Large separation** between wash and rinse (21" upper, 22" lower) avoids splashing of soiled water onto sanitized ware
- **Front-sloping tanks** for complete drainage and easier cleaning
- **External, easily-operated lever drain system** makes draining fast, safe and simple

#### Options:

- Choice of two clearance heights (standard 18" or high hood 26")
- Internal booster heater (steam or electric heat)
- External booster heater (steam or electric heat)
- Master disconnect
- External vent fan control
- Table limit switch
- Vent cowl collars
- 90° loaders and power unloaders
- Flanged feet
- Drain water tempering kit
- Shock arrestor

#### Standard Features:

- Capacity 260 racks per hour
- Water consumption, standard-height machines (K-76E, K-76S)
  - 105.0 U.S. gallons per hour
  - **0.40 U.S. gallons per rack**
- Water consumption, high-hood machines (K-76ET, K-76ST)
  - 234.0 U.S. gallons per hour
  - 0.90 gallons per rack
- All 304-series stainless steel construction
- Double-wall insulated construction on front, top and back to improve operator safety, conserve heating energy, and reduce noise and heat loss into the dishroom
- Large, easily-removed pan strainers with separate prewash scrap basket
- Fully automatic operation including auto-fill and auto-start. Prewash, wash and final rinse are activated only when a rack is in place to conserve water and detergent
- Powerful 3hp wash pump. All pumps are vertically-mounted to be self-draining and easily removed for servicing
- Electromechanical controls for reliability and easy operation. Low-voltage 24VAC control circuit for operator safety
- Easily accessible detergent and rinse aid injection ports for fast and easy chemical dispenser installation
- Single-point electrical, water and drain connections. Internal booster heater option adds an additional terminal block for simpler replacement of an existing external booster heater
- Low-level heater protection

#### Models:

- K-76E: 18" vertical clearance, electric heat
- K-76S: 18" vertical clearance, steam coil heat
- K-76ET: 26" vertical clearance, electric heat
- K-76ST: 26" vertical clearance, steam coil heat



## K-76 SERIES, LEFT-TO-RIGHT OPERATION, WITHOUT INTERNAL BOOSTER HEATER

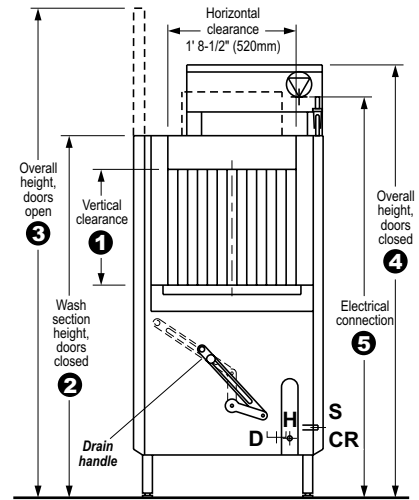
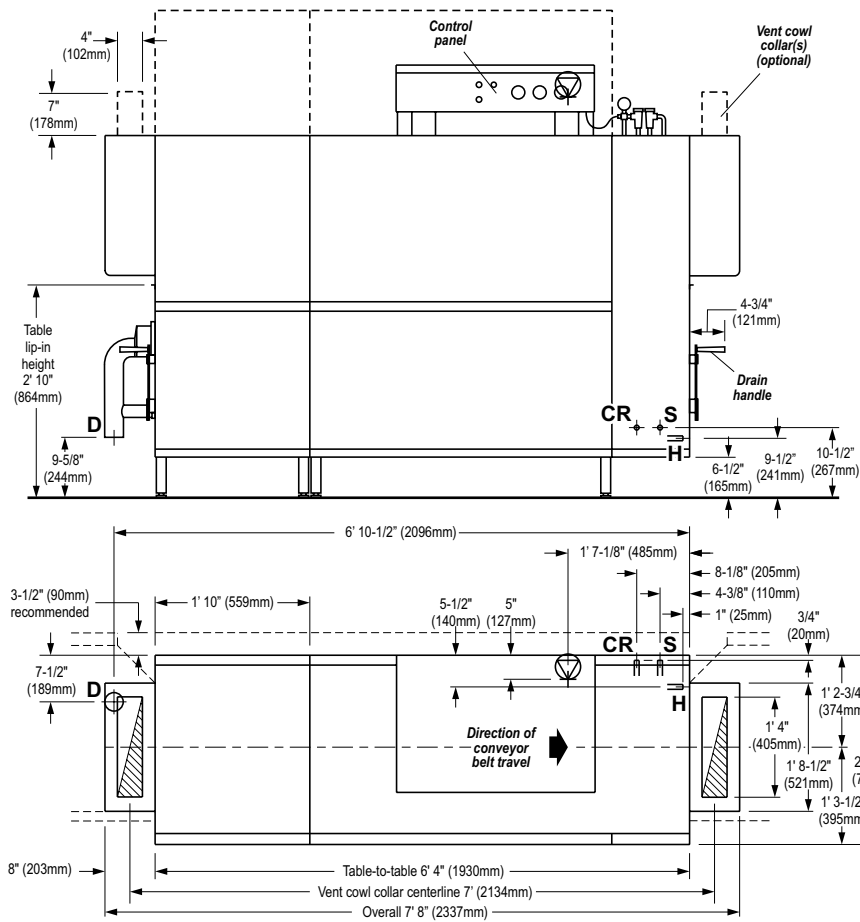

### Variable Dimensions

All dimensions from floor are +/- 1/2" due to adjustable feet.

- ① **Vertical clearance**  
Standard height: 1' 6" (457mm)  
Tall hood option: 2' 2" (660mm)
- ② **Wash section height**  
Standard height: 4' 9-7/8" (1471mm)  
Tall hood option: 5' 5-7/8" (1673mm)
- ③ **Overall height, doors open**  
Standard height: 6' 7-7/8" (2030mm)  
Tall hood option: 7' 11-7/8" (2435mm)
- ④ **Overall height, doors closed**  
Standard height: 5' 9-1/8" (1756mm)  
Tall hood option: 6' 5-1/8" (2435mm)
- ⑤ **Electrical connection height AFF**  
Standard height: 5' 4" (1626mm)  
Tall hood option: 6' (1829mm)

## K-76 SERIES, RIGHT-TO-LEFT OPERATION, WITHOUT INTERNAL BOOSTER HEATER

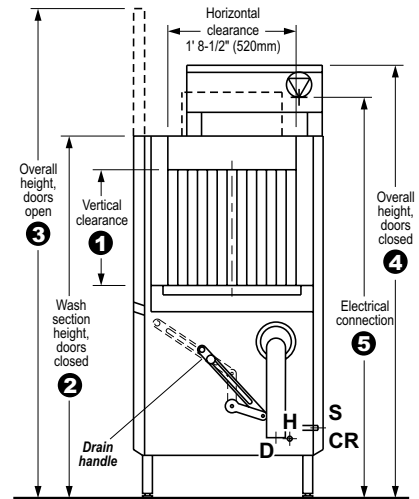
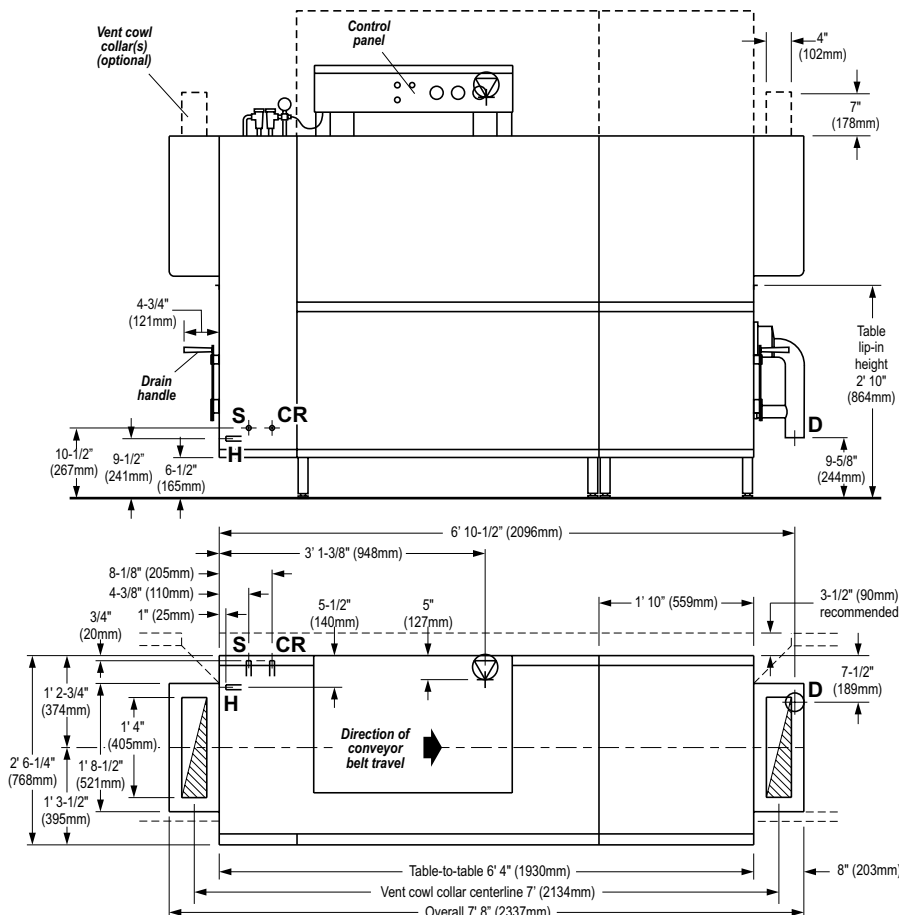

### Variable Dimensions

All dimensions from floor are +/- 1/2" due to adjustable feet.

- ① **Vertical clearance**  
Standard height: 1' 6" (457mm)  
Tall hood option: 2' 2" (660mm)
- ② **Wash section height**  
Standard height: 4' 9-7/8" (1471mm)  
Tall hood option: 5' 5-7/8" (1673mm)
- ③ **Overall height, doors open**  
Standard height: 6' 7-7/8" (2030mm)  
Tall hood option: 7' 11-7/8" (2435mm)
- ④ **Overall height, doors closed**  
Standard height: 5' 9-1/8" (1756mm)  
Tall hood option: 6' 5-1/8" (2435mm)
- ⑤ **Electrical connection height AFF**  
Standard height: 5' 4" (1626mm)  
Tall hood option: 6' (1829mm)

# K-76 SERIES, LEFT-TO-RIGHT OPERATION, WITH INTERNAL BOOSTER HEATER

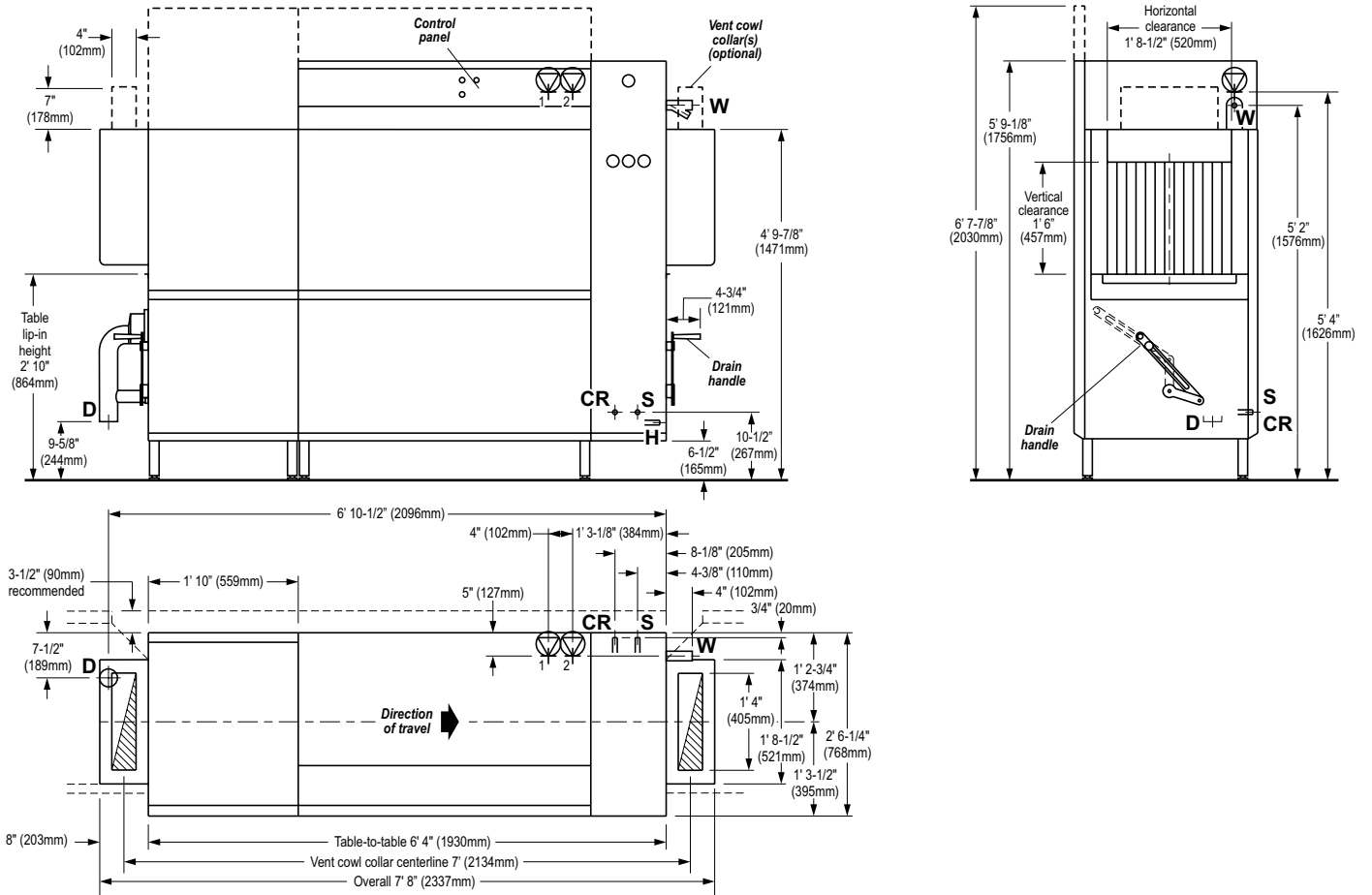

# K-76 SERIES, RIGHT-TO-LEFT OPERATION, WITH INTERNAL BOOSTER HEATER

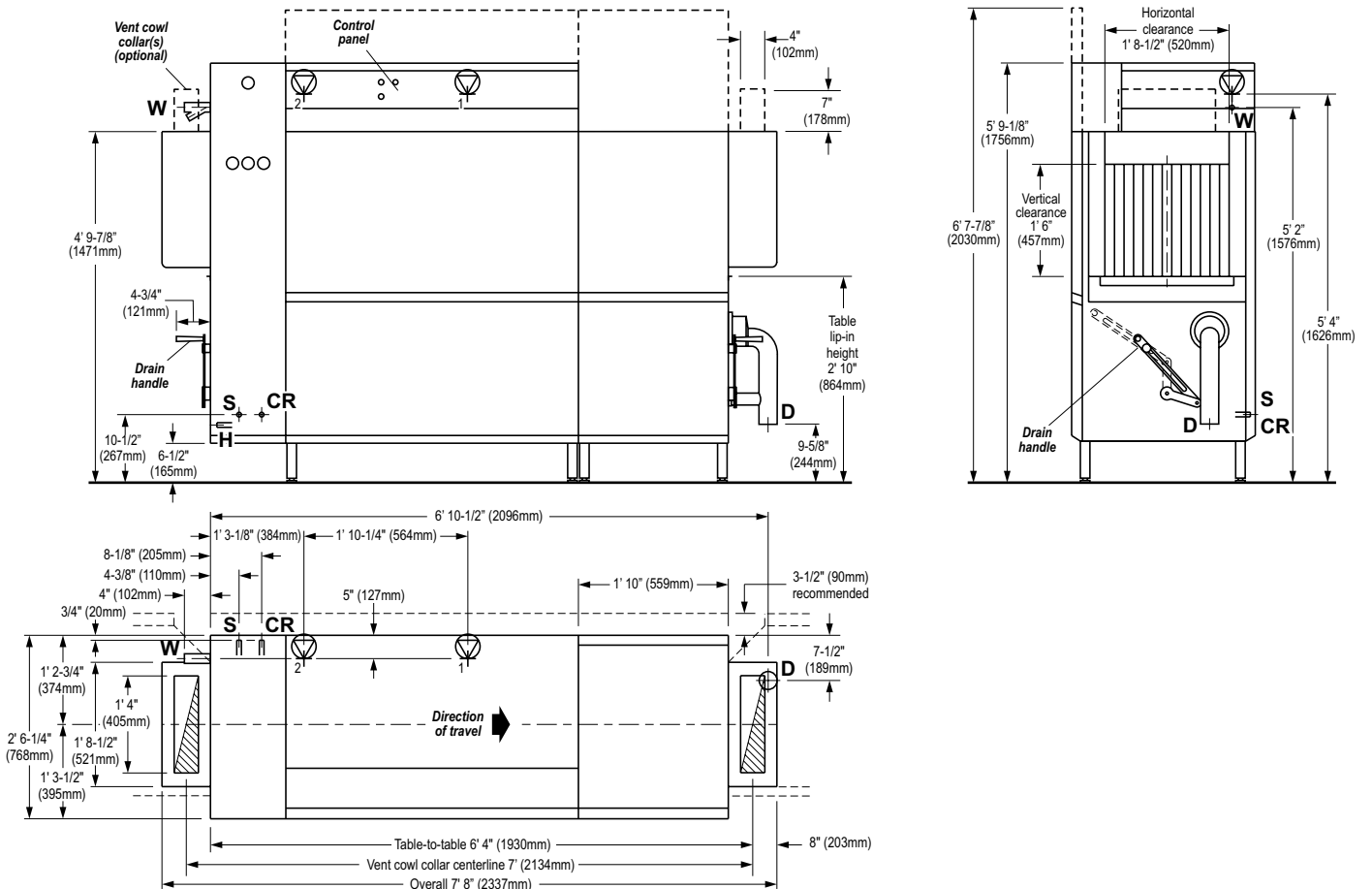

# K-76 SERIES UTILITY CONNECTIONS

## D Drain

2-15/16" (75mm) OD vertical, gravity-fed drain outlet (HDPE piping). Recommend placement directly above 4" floor drain. Additional piping to drain (if so required) to be supplied by customer.

Connection is 9-5/8" (244mm) AFF. If using optional 2" NPT adapter, connection is 8-1/2" (214mm) AFF. Refer to **Detail View: Drain** for suggested connection.



## Single electrical connection - machines without internal booster heater

- Single terminal block inside control box (4-wire with ground - no neutral).

## Dual electrical connections - machines with internal electric booster heater

- Two terminal blocks inside control box (4-wire with ground - no neutral).

- 1 - Machine electrical supply
- 2 - Booster heater electrical supply

Electrical supply (or supplies) should be routed into control box through strain relief(s) on rear of control box. Incoming leads must be appropriately sized for electrical supply. Individual disconnect with lockout/tagout strongly recommended (provided by customer).

Connection for standard-height machines is 5' 4" (1626mm) AFF. Connection for tall hood machines is 6' (1829mm) AFF.

Refer to utility chart on Page 5 for electrical load information.



## Vent connection - machines with optional vent cowl collars

Refer to **Detail View: Vent** for suggested connection.

The waste air connection must be corrosion-resistant and frost-free. In particular, provisions must be made to prevent air temperatures of 32°F/0°C or colder from reaching the machine at any time. A provision for draining moisture from the waste air pipe is strongly recommended.

- Load end - 200 CFM
- Unload end - 350 CFM
- Total - 550 CFM

## H Hot water connection - machines without internal booster heater

3/4" NPT female pipe connection is 9-1/2" (241mm) AFF.

- Temperature 180°F (82°C)
- Pressure 15-25 PSI
- Initial fill 50.3 U.S. gals. (190.4 liters)
- Consumption: Refer to utility chart on Page 5
- Recommended hardness 1-6 grains/U.S. gal.

## W Water connection - machines with internal booster heater only

3/4" NPT female pipe connection is 9-1/2" (241mm) AFF.

- Temperature:  
Machines with 40°F booster: 140°F (60°C)  
Machines with 70°F booster: 110°F (43°C)
- Pressure 15-25 PSI
- Initial fill 50.3 U.S. gals. (190.4 liters)
- Consumption: Refer to utility chart on Page 5
- Recommended hardness 1-6 grains/U.S. gal.

## S Steam connection - steam-heated machines

3/4" NPT male pipe connection is 10-1/2" (267mm) AFF.

- Pressure 10-30 PSI. Consult factory if steam pressure is below 10 PSI. If pressure is above 30 PSI, use of a regulator is REQUIRED (supplied by customer).
- Consumption: Refer to utility chart on Page 5

## CR Condensate return connection - steam-heated machines

3/4" NPT male pipe connection is 10-1/2" (267mm) AFF. Condensate line MUST be pressure-free.

## DETAIL VIEW: VENT

Machines equipped with optional vent cowl collars may be installed underneath a ventilation hood, or may use "pant leg" ventilation ducts (to be supplied by the customer). To determine the dimensions of the duct, first determine how they will be installed:

- **Duct sleeved outside collar**  
Inside dimensions of duct: 4" W x 16" D (102 x 406mm).
- **Duct sleeved inside collar**  
Outside dimensions of duct: 3-3/4" W x 15-3/4" D (95 x 400mm).

The duct must not interfere with the adjustable baffle, as shown.

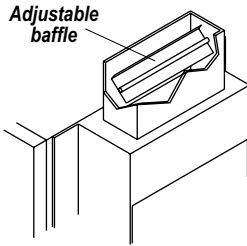

### Duct sleeved outside collar (recommended)

4" x 16" (102x406mm)  
inside dimensions

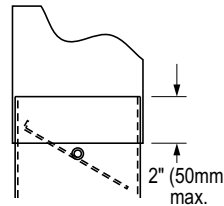

### Duct sleeved inside collar (if required)

3-3/4" x 15-3/4" (95x400mm)  
outside dimensions

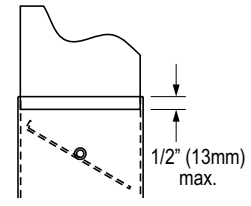

## DETAIL VIEW: DRAIN

The machine is equipped with a 2-15/16" (75mm) OD vertical, gravity-fed drain. If possible, the machine drain can simply be positioned directly above a 4" floor drain.

If a floor drain is not in the correct location, or if local codes require a trap, a 2" indirect drain line may be attached using the supplied boot, clamp, and 2" NPT male adapter.

Choose a piping material that:

- Complies with any applicable local and national codes
- Is rated for use with water temperatures up to 180°F/82°C
- Is rated for 3-12 pH to accommodate detergents and rinse aid in the drain water

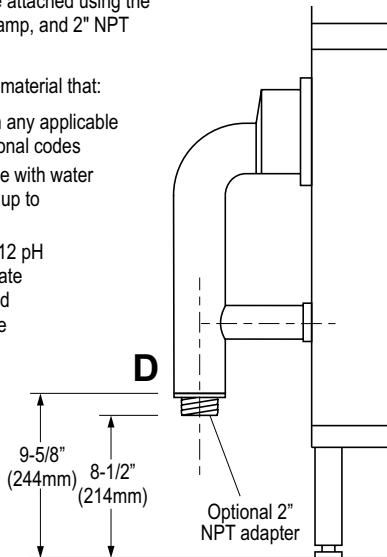

## DETAIL VIEW: TABLING

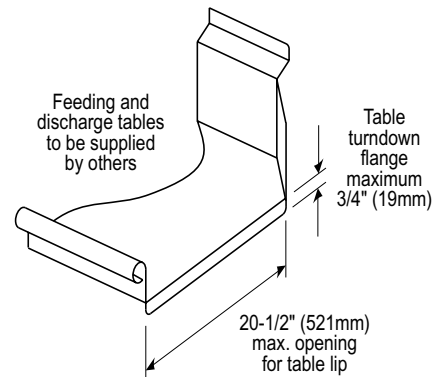
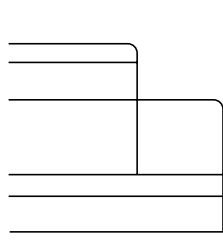

### Outside view

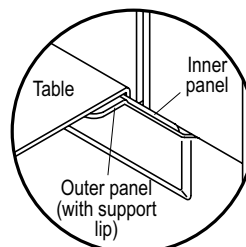

### Inside view

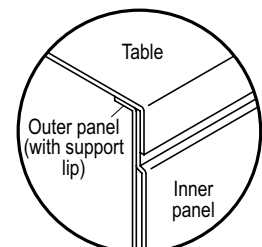

Check that the table lip overlaps BOTH the inner and outer panels.

Use silicone sealer between the table lip and the machine to prevent leakage.

# K-76 Series Technical Specifications

## Operating Capacities (NSF Rated)

|                        |      |
|------------------------|------|
| Racks per hour .....   | 260  |
| Dishes per hour .....  | 6500 |
| Glasses per hour ..... | 9360 |

## Conveyor Specifications

|   |                   |
|---|-------------------|
| Conveyor belt speed .....                 | 7' 3" (2.2m)/min. |
| Horizontal clearance .....                | 1' 8-1/2" (520mm) |
| Vertical clearance (K-66E, K-66S) .....   | 1' 6" (457mm)     |
| Vertical clearance (K-66ET, K-66ST) ..... | 2' 2" (660mm)     |

## Venting Specifications

|                  |                                |
|------------------|--------------------------------|
| Load end .....   | 200 CFM (336m <sup>3</sup> /h) |
| Unload end ..... | 350 CFM (588m <sup>3</sup> /h) |
| Total .....      | 550 CFM (924m <sup>3</sup> /h) |

## Shipping Information

|                       |  |
|-----------------------|--|
| K-76E, K-76S:         |  |
| Machine weight .....  | 788 lbs. (358kg)                       |
| Shipping weight ..... | 877 lbs. (398kg)                       |
| Crating (LxWxH) ..... | 8' 3" x 3' x 6' 3" (2.5 x 0.9 x 1.9m)  |
|                       | 154.7 cu. ft. (4.3m <sup>3</sup> )     |
| K-76ET, K-76ST:       |  |
| Machine weight .....  | 878 lbs. (399kg)                       |
| Shipping weight ..... | 967 lbs. (439kg)                       |
| Crating (LxWxH) ..... | 8' 3" x 3' x 6' 11" (2.5 x 0.9 x 2.1m) |
|                       | 171.2 cu. ft. (4.8m <sup>3</sup> )     |

## Water Specifications

|   |                                |
|---|--------------------------------|
| Minimum water temperatures:             |                                |
| Prewash tank .....                      | 110-140°F (43-60°C)            |
| Wash tank .....                         | 160°F (72°C)                   |
| Final rinse .....                       | 180°F (82°C)                   |
| Minimum incoming water temperature:     |                                |
| Machines without internal booster ..... | 180°F (82°C)                   |
| Machines with internal booster .....    | 110° or 140°F (43° or 60°C)    |
| Initial fill .....                      | 42.3 U.S. gals. (160.1 liters) |
| Wash tank capacity .....                | 33.1 U.S. gals. (125.3 liters) |
| Prewash tank capacity .....             | 17.2 U.S. gals. (65.1 liters)  |

|                                  |                                     |
|----------------------------------|-------------------------------------|
| Incoming water line size .....   | 3/4" NPT                            |
| Recommended water hardness ..... | 1-6 grains/U.S. gal.                |
| Consumption at 100% capacity:    |                                     |
| K-76E, K-76S .....               | 105.0 U.S. gals. (397.5 liters)/hr. |
|                                  | 0.40 U.S. gals. (1.53 liters)/rack  |
| K-76ET, K-76ST .....             | 234.0 U.S. gals. (887.5 liters)/hr. |
|                                  | 0.90 U.S. gals. (3.41 liters)/rack  |
| Final rinse flow pressure .....  | 15-25 PSI (1.0-1.7 bars)            |
| Flow rate (K-76E, K-76S) .....   | 1.75 U.S. gals.(6.62 liters)/min.   |
| Flow rate (K-76ET, K-76ST) ..... | 3.90 U.S. gals.(14.76 liters)/min.  |

## Electrical Specifications

| Machine supply connection   | Peak current draw | Minimum supply circuit ampacity | Maximum breaker/disconnect | Internal booster heater supply connection                        | Rating, machine startup | Rating, machine operation | Peak current draw | Minimum supply circuit ampacity | Maximum breaker/disconnect |
|---|-------------------|---------------------------------|----------------------------|--|-------------------------|---------------------------|-------------------|---------------------------------|----------------------------|
| K-76E (standard height, electric tank heat)                         |                   |                                 |                            | 40°F rise electric booster (140°F/60°C water supply temperature) |                         |                           |                   |                                 |                            |
| 208V/60 Hz/3 Ph   | 54.4 A            | 95 A                            | 85 A                       | 208V/60 Hz/3 Ph  | 14.4 kW                 | 9.6 kW                    | 40.0 A            | 55 A                            | 50 A                       |
| 230V/60 Hz/3 Ph   | 49.3 A            | 75 A                            | 65 A                       | 230V/60 Hz/3 Ph  | 14.4 kW                 | 9.6 kW                    | 36.1 A            | 55 A                            | 50 A                       |
| 460V/60 Hz/3 Ph   | 24.6 A            | 55 A                            | 50 A                       | 460V/60 Hz/3 Ph  | 14.4 kW                 | 9.6 kW                    | 18.1 A            | 30 A                            | 25 A                       |
| K-76ET (tall hood, electric tank heat)                              |                   |                                 |                            | 70°F rise electric booster (110°F/43°C water supply temperature) |                         |                           |                   |                                 |                            |
| 208V/60 Hz/3 Ph   | 66.7 A            | 95 A                            | 85 A                       | 208V/60 Hz/3 Ph  | 28.8 kW                 | 21.6 kW                   | 79.9 A            | 110 A                           | 100 A                      |
| 230V/60 Hz/3 Ph   | 58.0 A            | 85 A                            | 75 A                       | 230V/60 Hz/3 Ph  | 28.8 kW                 | 21.6 kW                   | 72.3 A            | 110 A                           | 100 A                      |
| 460V/60 Hz/3 Ph   | 28.4 A            | 55 A                            | 50 A                       | 460V/60 Hz/3 Ph  | 28.8 kW                 | 21.6 kW                   | 36.1 A            | 55 A                            | 50 A                       |
| K-76S, K-76ST (standard height and tall hood, steam coil tank heat) |                   |                                 |                            | Electric tank heat:  |                         |                           |                   |                                 |                            |
| 208V/60 Hz/3 Ph   | 12.7 A            | 30 A                            | 20 A                       | Wash tank  | 208V/60Hz/3Ph           | 230V/60Hz/3Ph             | 460V/60Hz/3Ph     |                                 |                            |
| 230V/60 Hz/3 Ph   | 12.8 A            | 30 A                            | 20 A                       | K-66E  | 15.0 kW                 | 14.6 kW                   | 15.0 kW           |                                 |                            |
| 460V/60 Hz/3 Ph   | 5.8 A             | 25 A                            | 15 A                       | K-66ET   | 19.5 kW                 | 18.0 kW                   | 18.0 kW           |                                 |                            |
|   |                   |                                 |                            | Wash pump motor .....  |                         |                           |                   |                                 | 3.0 hp                     |
|   |                   |                                 |                            | Prewash pump motor .....   |                         |                           |                   |                                 | 0.75 hp                    |
|   |                   |                                 |                            | Conveyor motor .....   |                         |                           |                   |                                 | 0.125 hp                   |

## Steam Specifications (K-76S, K-76ST)

|   |                          |
|---|--------------------------|
| Steam line connection .....   | 3/4" NPT                 |
| Condensate return connection .....                                  | 3/4" NPT                 |
| Steam pressure .....  | 10-30 psi (0.7-2.0 bars) |
| Consumption:  |                          |
| K-76S .....   | 60 lbs./hr.              |
| K-76ST .....  | 60 lbs./hr.              |
| Internal Steam Booster Heater:                                      |                          |
| 40°F rise steam booster (140°F/60°C water supply temperature) ..... | 50 lbs./hr.              |
| 70°F rise steam booster (110°F/43°C water supply temperature) ..... | 100 lbs./hr.             |

## External Booster Heater Recommendations (for machines without optional internal booster heater)

Booster ratings are based on peak capacity of 105.0 U.S. gals./hr. and a flow rate of 1.75 U.S. gals./min. for models K-76E and K-76S; peak capacity of 234.0 U.S. gals./hr. and a flow rate of 3.90 U.S. gals./min. for models K-76ET and K-76ST. Recommended boosters are one size larger than required to help compensate for any local conditions that may prevent full performance.

|                | Water supply temperature | Required temperature rise | Recommended booster rating |
|----------------|--------------------------|---------------------------|----------------------------|
| K-76E, K-76S   | 110°F/43°C               | 70°F/39°C                 | 24 kW                      |
|                | 140°F/60°C               | 40°F/22°C                 | 12 kW                      |
| K-76ET, K-76ST | 110°F/43°C               | 70°F/39°C                 | 45 kW                      |
|                | 140°F/60°C               | 40°F/22°C                 | 27 kW                      |

# Equipment Specification: K-76 Rack Conveyor Warewasher - Item No. \_\_\_\_\_

Item will be a **K-76** single tank, rack conveyor dishmachine, consisting of a prewash zone with a 3/4 hp pump motor, a wash zone with a 3 hp pump motor, and a final rinse zone. Total length of the tank section (not including vent cowls) will be 6' 4" (1930mm). Unit will utilize a 180°F/82°C minimum fresh water sanitizing rinse.

Unit will have a capacity of 260 racks per hour at an NSF-rated belt speed of 7' 3" (2.2m) per minute. Standard-height units will consume an NSF-rated 105.0 U.S. gals./397.5ℓ per hour (0.40 U.S. gals./1.53ℓ per rack). Tall-hood units will consume an NSF-rated 234.0 U.S. gals./885.7ℓ per hour (0.90 U.S. gals./3.41ℓ per rack).

The dishmachine will be NSF, UL and CUL listed.

Electrical characteristics:

- 208V/60 Hz/3 Ph
- 230V/60 Hz/3 Ph
- 460V/60 Hz/3 Ph

Wash tank temperature will be maintained at a minimum of 160°F/72°C. Tank heating will be accomplished by:

- Thermostatically-controlled electric heating elements (K-76E, K-76ET)
- Thermostatically-controlled stainless steel steam coils (K-76S, K-76ST)

Direction of conveyor travel will be:

- Right-to-Left
- Left-to-Right

Unit will have the following standard features:

- Double-wall, insulated construction on top, front, and rear.
- Two upper prewash arms and one lower prewash arm.
- Five upper wash arms with 19" (483mm) wash area and five lower wash arms with 18" (457mm) wash area.
- Wash arm spray pattern ensures effective coverage with varying angles and offset spray jets. Slotted, concave wash nozzles and captivated end caps for easier cleaning.
- Minimum separation between wash and final rinse of 21" (533mm) upper and 22" (533mm) lower.
- Exclusive synchronized rack rail pawl bar system for smooth rack movement. Side drive system provides easy cleaning access and eliminates wash pattern obstruction.
- Front-sloping tanks for complete tank drainage, accessibility, and cleanability.
- Fully automatic operation including auto-fill and auto-start.
- Separate compartment actuator switches to ensure prewash, wash and rinse are energized only when a rack is in place.
- External, easily operable, lever-operated drain system.
- Low level heater protection.
- Prewash, wash and recirculating rinse pump motors are self-draining, internal and vertically installed for easy access and serviceability.
- Pump housing and impeller constructed of stainless steel.
- Totally electromechanical controls with a 24 VAC control circuit.
- Single point electrical connection.
- Easily removable wash arm block manifold systems, prewash arms, and final rinse arms.
- Large front access doors can be opened with one hand and remain open without latches, aiding machine accessibility and cleanability.
- Large, removable stainless pan strainers with separate prewash scrap basket.
- Built-in pressure regulator.
- Single point drain connection.

Unit will have the following optional features (check all that apply):

- |   |   |
|---|---|
| <input type="checkbox"/> Tall hood option to increase vertical clearance from 1' 6" (457mm) to 2' 2" (660mm)  | <input type="checkbox"/> External vent fan control  |
| <input type="checkbox"/> Internal booster heater (steam or electric per machine spec). Electrically-heated internal booster heater adds 1 electrical terminal block to machine (2 total). | <input type="checkbox"/> Table limit switch   |
| <input type="checkbox"/> Sized for a minimum 40°F (22°C) rise and 140°F (60°C) min. incoming water temperature  | <input type="checkbox"/> Inline (whisker switch) style  |
| <input type="checkbox"/> Sized for a minimum 70°F (39°C) rise and 110°F (43°C) min. incoming water temperature  | <input type="checkbox"/> End stop style   |
| <input type="checkbox"/> External booster heater  | <input type="checkbox"/> Vent cowl collar(s) with adjustable damper 4" W x 16" D x 7" H (102x406x178mm) |
| <input type="checkbox"/> Sized for a minimum 40°F (22°C) rise and 140°F (60°C) min. incoming water temperature  | <input type="checkbox"/> At both ends   |
| <input type="checkbox"/> Sized for a minimum 70°F (39°C) rise and 110°F (43°C) min. incoming water temperature  | <input type="checkbox"/> At load end only   |
| <input type="checkbox"/> Steam heated   | <input type="checkbox"/> At unload end only   |
| <input type="checkbox"/> Electrically heated  | <input type="checkbox"/> 90° side loader (unhooded), 23" long   |
| <input type="checkbox"/> Master disconnect  | <input type="checkbox"/> 90° side loader (hooded), 23" long   |
|   | <input type="checkbox"/> 90° power loader, 34-1/4" long   |
|   | <input type="checkbox"/> 90° power unloader, 34-1/4" long   |
|   | <input type="checkbox"/> Flanged feet for permanent installation  |
|   | <input type="checkbox"/> Drain water tempering kit  |
|   | <input type="checkbox"/> Shock arrestor   |