



K-64 SERIES

HOT WATER SANITIZING MULTIPLE-TANK RACK CONVEYOR WAREWASHERS

Exclusive Features:

- **Synchronized side-drive dual rack rail pawl-bar system** ensures complete water coverage from every angle, even the bottom of the rack
- **Large, insulated front door** is spring-loaded to open easily and STAY open, without latching
- **Computer-positioned wash arms** in easily-removed manifolds. Arms and manifolds are stainless steel, eliminating high-wear gaskets and O-rings
- **Concave, slotted nozzles** minimize clogging. Nozzles are computer-positioned at varying angles to maximize water coverage over all areas of the ware
- **Powerful 3hp pumps** are 50% more powerful than the industry standard for outstanding cleaning
- **Large separation** between wash and rinse (14" upper, 15" lower) avoids splashing of soiled water onto sanitized ware
- **Front-sloping tanks** for complete drainage and easier cleaning
- **External, easily-operated lever drain system** makes draining fast, safe and simple

Standard Features:

- **ENERGY STAR** Qualified
- Capacity **284** racks per hour
- Water consumption **0.37** gallons per rack
- All 304-series stainless steel construction
- Double-wall insulated construction on front, top and back to improve operator safety, conserve heating energy, and reduce noise and heat loss into the dishroom
- Large, easily-removed pan strainers
- Fully automatic operation including auto-fill and auto-start. Wash, recirculating rinse and final rinse are activated only when a rack is in place to conserve water and detergent
- Powerful 3hp wash and recirculating rinse pumps are vertically-mounted to be self-draining and easily removed for servicing
- Electromechanical controls for reliability and easy operation. Low-voltage 24VAC control circuit for operator safety
- Easily accessible detergent and rinse aid injection ports for fast and easy chemical dispenser installation
- Single-point electrical, water and drain connections. Internal booster heater option adds an additional terminal block for simpler replacement of an existing external booster heater
- Low-level heater protection
- Pressure reduction valve (machines with internal booster heater)



Options:

- Choice of two clearance heights (standard 18" or tall hood 26")
- Internal booster heater (steam or electric heat)
- External booster heater (steam or electric heat)
- Master disconnect
- External vent fan control
- Table limit switch
- Vent cowl collars
- Direct drive sideloader
- 90° powered loader or unloaders
- Flanged feet
- Drain water tempering kit
- Shock arrestor
- Pressure reduction valve (machines without internal booster heater)

Models:

- K-64E: 18" vertical clearance, electric heat
- K-64S: 18" vertical clearance, steam coil heat
- K-64ET: 26" vertical clearance, electric heat
- K-64ST: 26" vertical clearance, steam coil heat



K-64 Series, left-to-right - electric heat w/o internal booster *OR* steam heat (all)

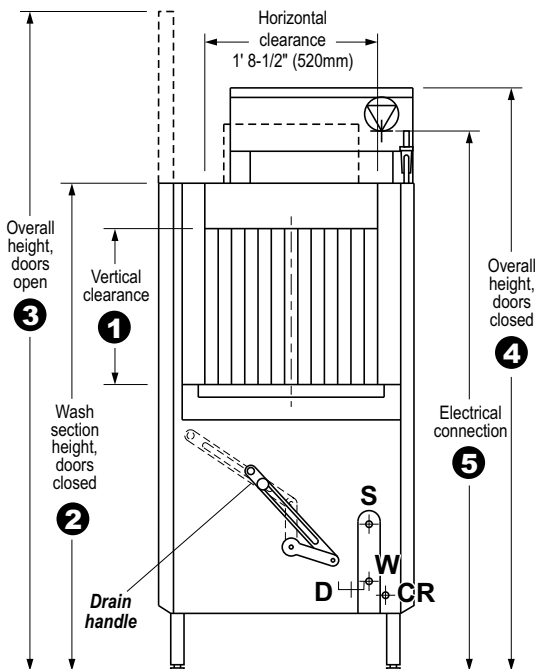
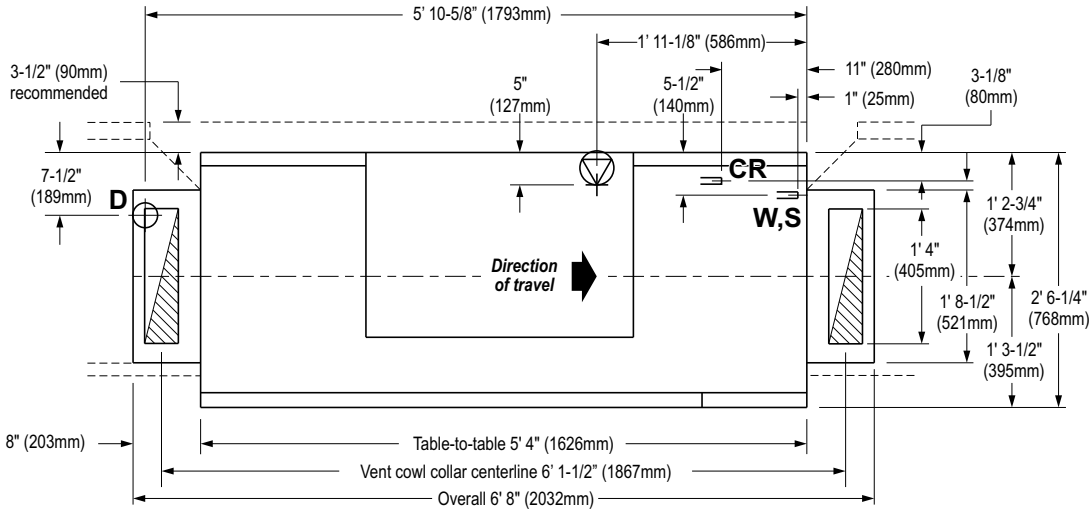
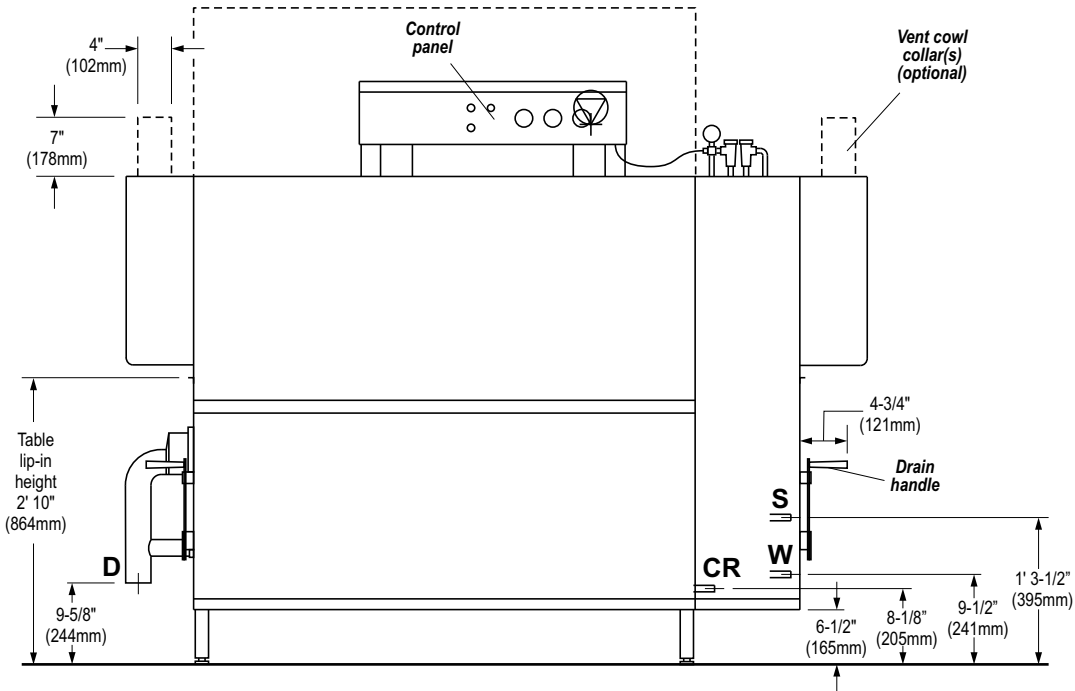

Variable Dimensions

All dimensions from floor are +/- 1/2" due to adjustable feet.

	Standard height machines	Tall hood machines
①	1' 6" (457mm)	2' 2" (660mm)
②	4' 9-7/8" (1471mm)	5' 5-7/8" (1673mm)
③	6' 7-7/8" (2030mm)	7' 11-7/8" (2435mm)
④	5' 9-1/8" (1756mm)	6' 5-1/8" (2435mm)
⑤	5' 4" (1626mm)	6' (1829mm)

Utility Connection Symbols

Utility ratings and connection specifications on Page 6.

D	Drain	W	Water
	Electrical	S	Steam
	Ventilation	CR	Condensate return

K-64 Series, right-to-left - electric heat w/o internal booster *OR* steam heat (all)

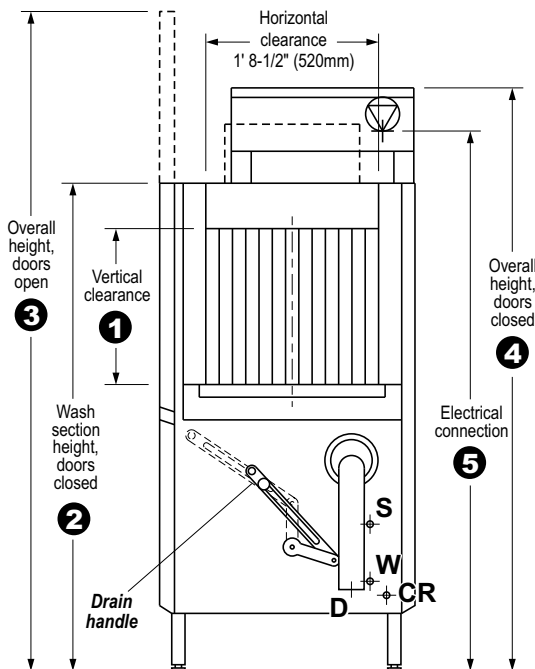
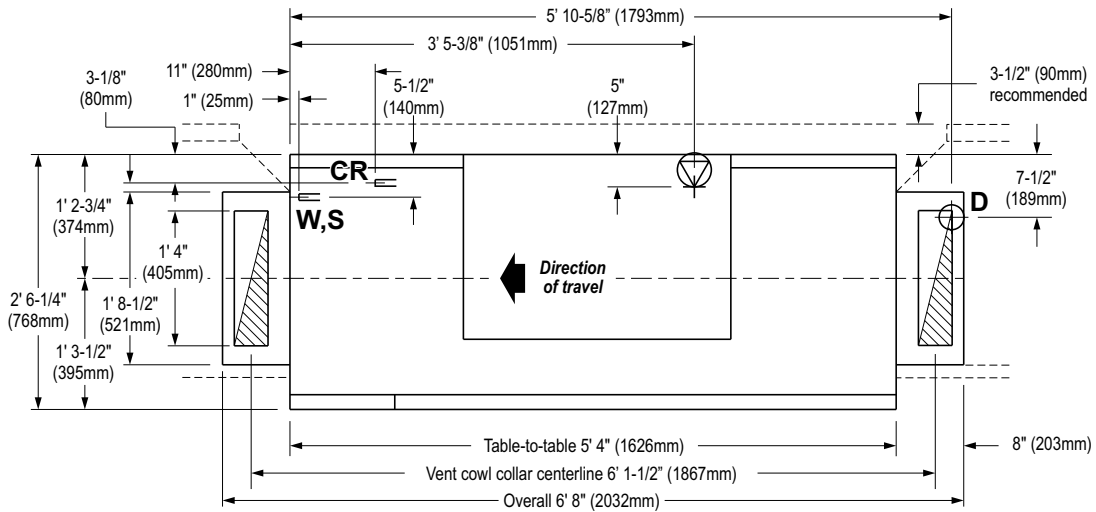
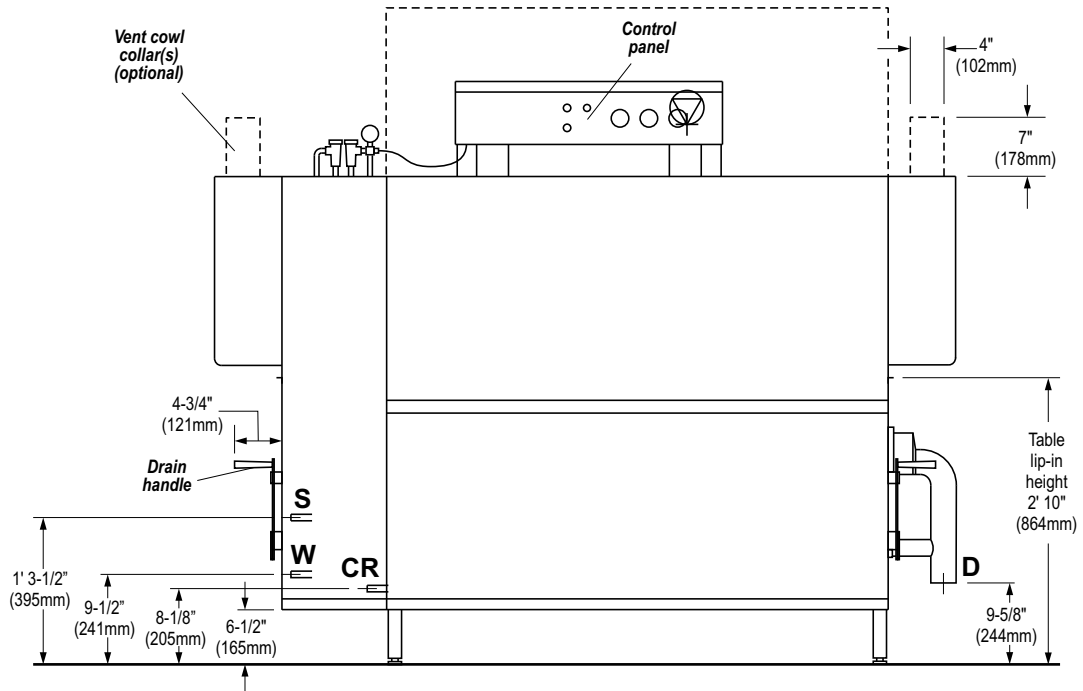

Variable Dimensions

All dimensions from floor are +/- 1/2" due to adjustable feet.

	Standard height machines	Tall hood machines
1	1' 6" (457mm)	2' 2" (660mm)
2	4' 9-7/8" (1471mm)	5' 5-7/8" (1673mm)
3	6' 7-7/8" (2030mm)	7' 11-7/8" (2435mm)
4	5' 9-1/8" (1756mm)	6' 5-1/8" (2435mm)
5	5' 4" (1626mm)	6' (1829mm)

Utility Connection Symbols

Utility ratings and connection specifications on Page 6.

- D** Drain
- W** Water
-  Electrical
- S** Steam
-  Ventilation
- CR** Condensate return

K-64 Series, left-to-right - electric heat with internal booster

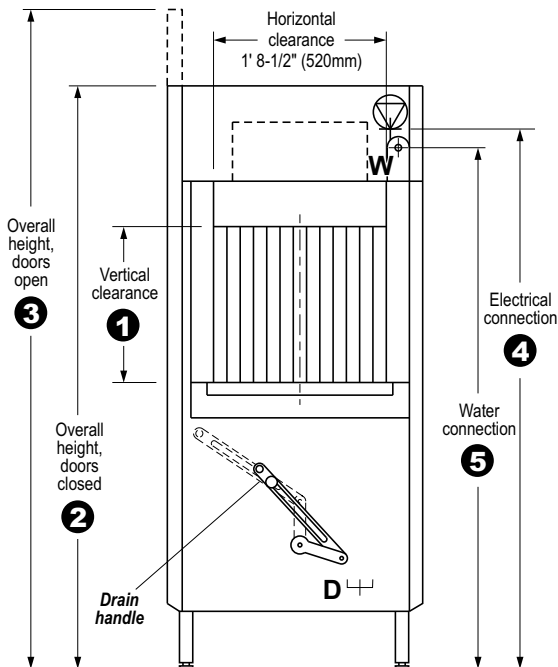
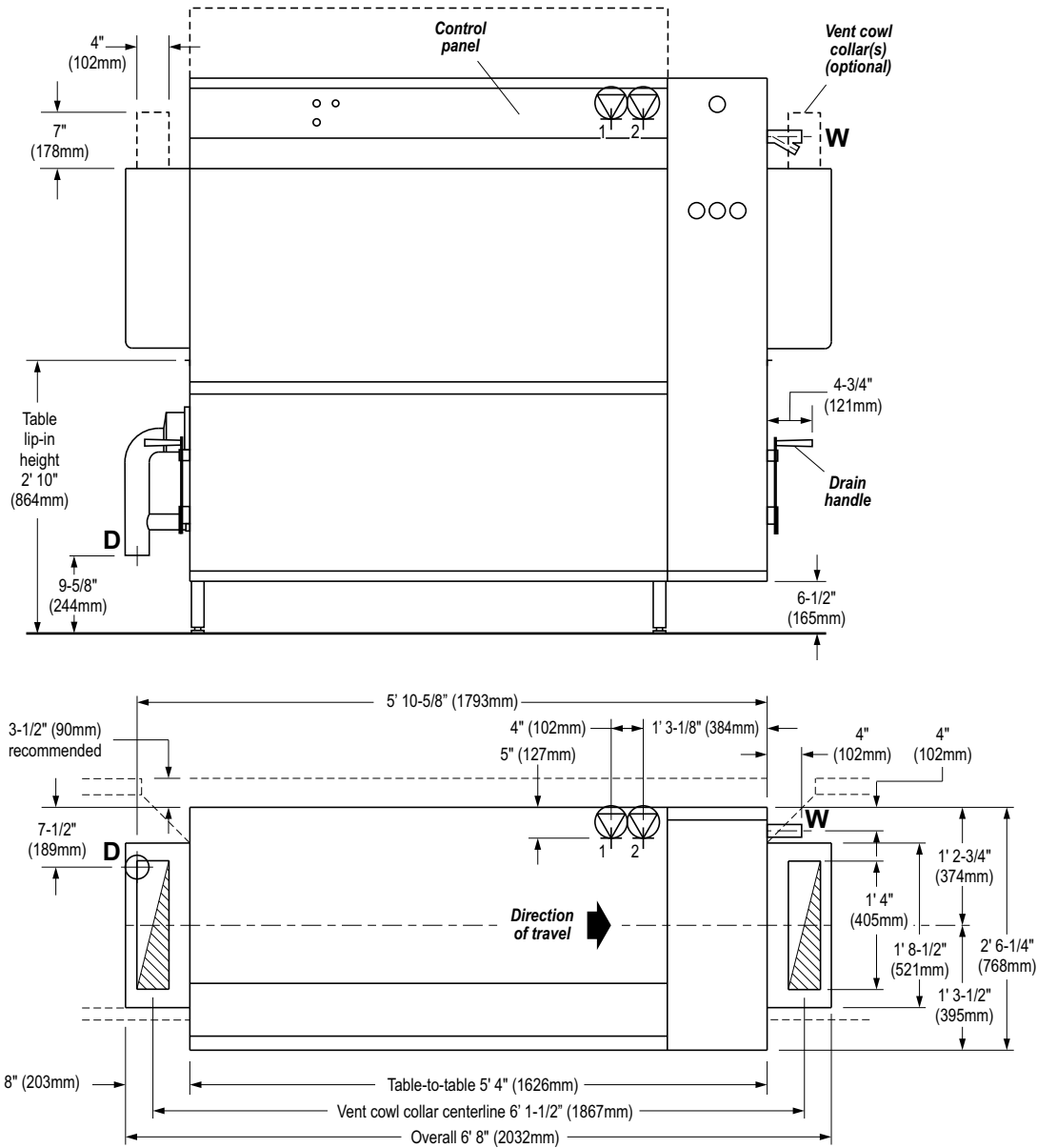

Variable Dimensions

All dimensions from floor are +/- 1/2" due to adjustable feet.

	Standard height machines	Tall hood machines
①	1' 6" (457mm)	2' 2" (660mm)
②	5' 9-1/8" (1756mm)	6' 5-1/8" (2435mm)
③	6' 7-7/8" (2030mm)	7' 11-7/8" (2435mm)
④	5' 4" (1626mm)	6' (1829mm)
⑤	5' 2" (1576mm)	5' 10" (1778mm)

Utility Connection Symbols

Utility ratings and connection specifications on Page 6.

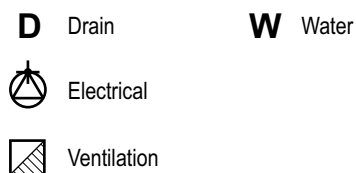

K-64 Series, right-to-left - electric heat with internal booster

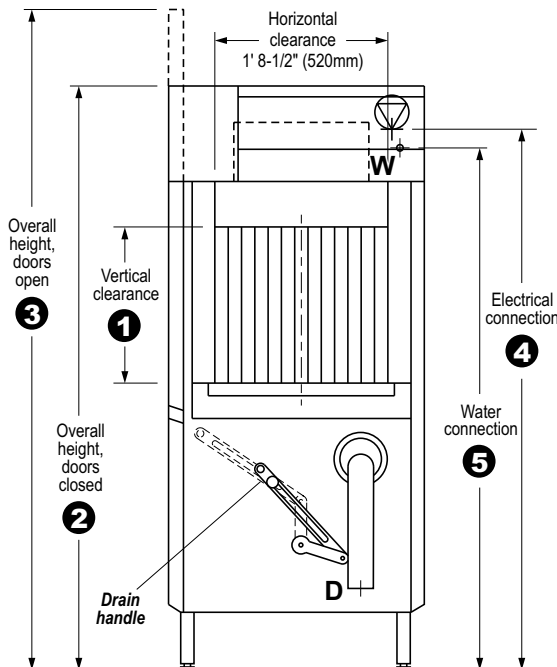
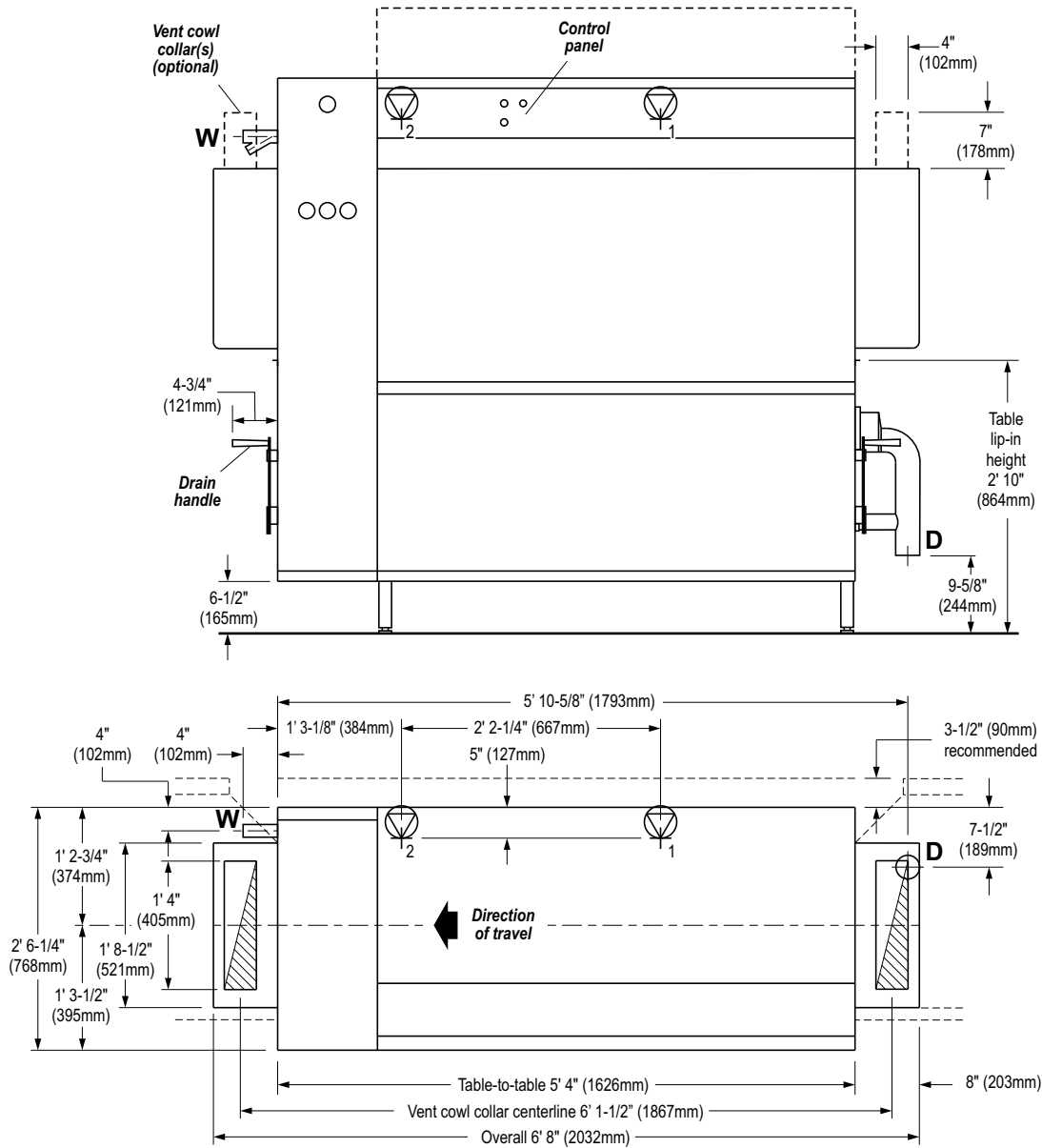

Variable Dimensions

All dimensions from floor are +/- 1/2" due to adjustable feet.

	Standard height machines	Tall hood machines
①	1' 6" (457mm)	2' 2" (660mm)
②	5' 9-1/8" (1756mm)	6' 5-1/8" (2435mm)
③	6' 7-7/8" (2030mm)	7' 11-7/8" (2435mm)
④	5' 4" (1626mm)	6' (1829mm)
⑤	5' 2" (1576mm)	5' 10" (1778mm)

Utility Connection Symbols

Utility ratings and connection specifications on Page 6.

- D** Drain
- W** Water
- Electrical
- Ventilation

K-64 Series Utility Connections

D Drain

2-15/16" (75mm) OD vertical, gravity-fed drain outlet (HDPE piping). Recommend placement directly above 4" floor drain. Additional piping to drain (if so required) to be supplied by customer.

Connection is 9-5/8" (244mm) AFF. If using optional 2" NPT adapter, connection is 8-1/2" (214mm) AFF. Refer to **Detail View: Drain** for suggested connection.



Single electrical connection

- Single terminal block inside control box (4-wire with ground - no neutral).

Dual electrical connections - machines with internal electric booster heater

- Two terminal blocks inside control box (4-wire with ground - no neutral).

- Machine electrical supply
- Booster heater electrical supply

Electrical supply (or supplies) should be routed into control box through strain relief(s) on rear of control box. Incoming leads must be appropriately sized for electrical supply. Individual disconnect with lockout/tagout strongly recommended (provided by customer).

Connection for standard-height machines is 5' 4" (1626mm) AFF. Connection for tall hood machines is 6' (1829mm) AFF.

Refer to utility chart on Page 7 for electrical load information.



Vent connection - machines with optional vent cowl collars

Refer to **Detail View: Vent** for suggested connection.

The waste air connection must be corrosion-resistant and frost-free. In particular, provisions must be made to prevent air temperatures of 32°F/0°C or colder from reaching the machine at any time. A provision for draining moisture from the waste air pipe is strongly recommended.

- Load end - 200 CFM
- Unload end - 350 CFM
- Total - 550 CFM

W Hot water connection - machines without internal booster heater

1/2" NPT female pipe connection is 9-1/2" (241mm) AFF.

- Temperature 180°F (82°C)
- Pressure 15-25 PSI
- Initial fill 41.0 U.S. gals. (155.2 liters)
- Consumption 105.0 U.S. gals per hour (397.5 liters) per hour
- Recommended hardness 1-6 grains/U.S. gal.

W Water connection - machines with internal booster heater only

For steam heat, 1/2" NPT female pipe connection is 9-1/2" (241mm) AFF. For electric heat, 1/2" NPT female pipe connection is 5' 2" (1576mm) AFF for standard-height, 5' 10" (1778mm) AFF with tall hood option.

- Temperature:
 - Machines with 40°F booster: 140°F (60°C)
 - Machines with 70°F booster: 110°F (43°C)
- Pressure 15-25 PSI
- Initial fill 41.0 U.S. gals. (155.2 liters)
- Consumption 105.0 U.S. gals per hour (397.5 liters) per hour
- Recommended hardness 1-6 grains/U.S. gal.

S Steam connection - steam-heated machines

3/4" NPT male pipe connection is 1' 3-1/2" (395mm) AFF.

- Pressure 10-30 PSI. Consult factory if steam pressure is below 10 PSI. If pressure is above 30 PSI, use of a regulator is REQUIRED (supplied by customer).
- Consumption: Refer to utility chart on Page 7

CR Condensate return connection - steam-heated machines

3/4" NPT male pipe connection is 8-1/8" (205mm) AFF. Condensate line MUST be pressure-free.

DETAIL VIEW: VENT

Machines equipped with optional vent cowl collars may be installed underneath a ventilation hood, or may use "pant leg" ventilation ducts (to be supplied by the customer). To determine the dimensions of the duct, first determine how they will be installed:

- Duct sleeved outside collar**
Inside dimensions of duct: 4" W x 16" D (102 x 406mm).
- Duct sleeved inside collar**
Outside dimensions of duct: 3-3/4" W x 15-3/4" D (95 x 400mm).

The duct must not interfere with the adjustable baffle, as shown.

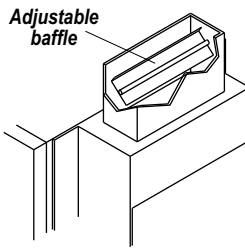

Duct sleeved outside collar (recommended)

4" x 16" (102x406mm)
inside dimensions

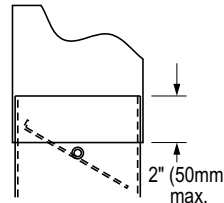

Duct sleeved inside collar (if required)

3-3/4" x 15-3/4" (95x400mm)
outside dimensions

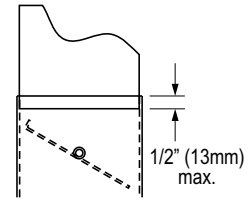

DETAIL VIEW: DRAIN

The machine is equipped with a 2-15/16" (75mm) OD vertical, gravity-fed drain. If possible, the machine drain can simply be positioned directly above a 4" floor drain.

If a floor drain is not in the correct location, or if local codes require a trap, a 2" indirect drain line may be attached using the supplied 2" NPT male adapter.

Choose a piping material that:

- Complies with any applicable local and national codes
- Is rated for use with water temperatures up to 180°F/82°C
- Is rated for 3-12 pH to accommodate detergents and rinse aid in the drain water

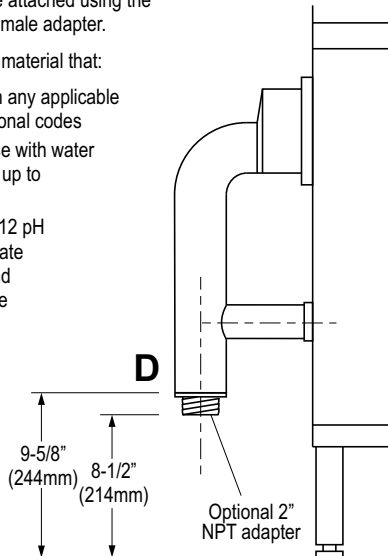

DETAIL VIEW: TABLING

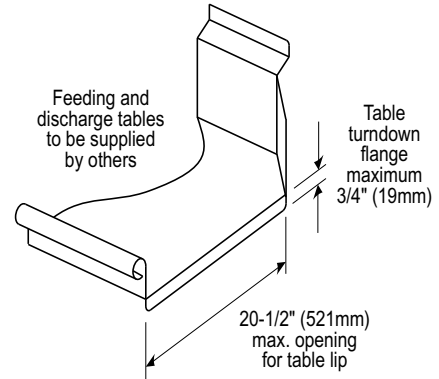
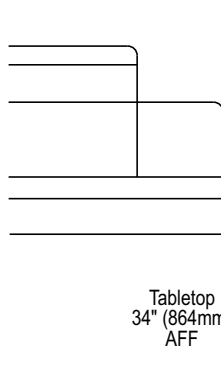

Outside view

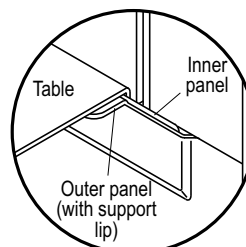

Inside view

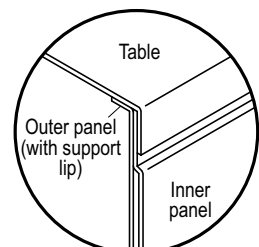

Check that the table lip overlaps BOTH the inner and outer panels.

Use silicone sealer between the table lip and the machine to prevent leakage.

Equipment Specification: K-64 Rack Conveyor Warewasher - Item No. _____

Item will be a **MEIKO K-64** multiple tank, rack conveyor dishmachine, consisting of a wash zone with a 3 hp pump motor, a recirculating rinse zone with a 3 hp pump motor, and a final rinse zone. Total length of the tank section (not including vent cowls) will be 5' 4" (1626mm). Unit will utilize a 180°F/82°C minimum fresh water sanitizing rinse.

Unit will have a capacity of 284 racks per hour at an NSF-rated belt speed of 7.91 feet (2.41m) per minute. Unit will consume an NSF-rated 105.0 U.S. gals./397.5 liters per hour (0.37 U.S. gals./1.40 liters per rack).

The dishmachine will be NSF, UL and CUL listed.

Electrical characteristics:

___ 208V/60 Hz/3 Ph

___ 230V/60 Hz/3 Ph

___ 460V/60 Hz/3 Ph

Wash tank temperature will be maintained at a minimum of 150°F/66°C. Recirculating rinse tank temperature will be maintained at a minimum of 160°F/72°C. Tank heating will be accomplished by:

___ Thermostatically-controlled electric heating elements (K-64E, K-64ET)

___ Thermostatically-controlled stainless steel steam coils (K-64S, K-64ST)

Direction of conveyor travel will be:

___ Right-to-Left

___ Left-to-Right

Unit will have the following standard features:

- Double-wall, insulated construction on top, front, and rear.
- Four upper wash arms with 15" (381mm) wash area and four lower wash arms with 14" (356mm) wash area.
- Four upper recirculating rinse arms with 15" (381mm) wash area and four lower recirculating rinse arms with 14" (356mm) wash area.
- Wash arm spray pattern ensures effective coverage with varying angles and offset spray jets. Slotted, concave wash nozzles and captivated end caps for easier cleaning.
- Minimum separation between recirculating rinse and final rinse of 14" (356mm) upper and 15" (381mm) lower.
- Exclusive synchronized rack rail pawl bar system for smooth rack movement. Side drive system provides easy cleaning access and eliminates wash pattern obstruction.
- Front-sloping tanks for complete tank drainage, accessibility, and cleanability.
- Fully automatic operation including auto-fill and auto-start.
- Separate compartment actuator switches to ensure wash, recirculating rinse and final rinse are energized only when a rack is in place.
- External, easily operable, lever-operated drain system.
- Low level heater protection.
- Wash and recirculating rinse pump motors are self-draining, internal and vertically installed for easy access and serviceability.
- Wash and recirculating rinse pump housings and impellers constructed of stainless steel.
- Electromechanical controls with a 24 VAC control circuit.
- Single point electrical connection.
- Easily removable wash and recirculating rinse arm block manifold systems and final rinse arms.
- Large front access door can be opened with one hand and remain open without latches, aiding machine accessibility and cleanability.
- Large, removable stainless pan strainers.
- Single point drain connection.
- Pressure reduction valve (machines with internal booster heater only).

Unit will have the following optional features (check all that apply):

___ Tall hood option to increase vertical clearance from 1' 6" (457mm) to 2' 2" (660mm)

___ Internal booster heater (steam or electric per machine spec). Electrically-heated internal booster heater adds 1 electrical terminal block to machine (2 total).

___ Sized for a minimum 40°F (22°C) rise and 140°F (60°C) min. incoming water temperature

___ Sized for a minimum 70°F (39°C) rise and 110°F (43°C) min. incoming water temperature

___ External booster heater

___ Sized for a minimum 40°F (22°C) rise and 140°F (60°C) min. incoming water temperature

___ Sized for a minimum 70°F (39°C) rise and 110°F (43°C) min. incoming water temperature

___ Steam heated

___ Electrically heated

___ Master disconnect

___ External vent fan control

___ Table limit switch

___ Inline (whisker switch) style

___ End stop style

___ Vent cowl collar(s) with adjustable damper 4" W x 16" D x 7" H (102x406x178mm)

___ At both ends

___ At load end only

___ At unload end only

___ 90° side loader (unhooded), 23" long

___ 90° side loader (hooded), 23" long

___ 90° power loader, 34-1/4" long

___ 90° power unloader, 34-1/4" long

___ Flanged feet for permanent installation

___ Drain water tempering kit

___ Shock arrestor

___ Pressure reduction valve (machines without internal booster heater only)