



DV 80.2

HOT WATER SANITIZING DOOR-TYPE DISHWASHER



Exclusive Features:

- **Auto Safe temperature control system** - Guarantees 180°F sanitizing final rinse temperature, regardless of incoming water temperature
- **Mike 2 electronic control system** - advanced micro-computer technology for service diagnostics and end-user dishmachine settings. Includes one-touch operation, one-touch selection of three different cycle lengths, automatic temperature monitoring with digital display, and advanced service diagnostics
- **Automatic push-handle start** - Pushing down on the door handle starts a cycle
- **Active Plus filtration system** - Double filtration of wash water removes food soil, improves washing efficiency and saves detergent while easing cleaning chores
- **Soft Start wash pump** - Protects dishes and glasses from chipping or breaking
- **Aqua-Stop** - Automatically turns off incoming water supply if leaking occurs
- **Built-in booster heater with power rinse pump** - Guarantees constant final rinse pressure and temperature for consistent, outstanding results

Standard Features:

- **ENERGY STAR** Qualified
- Capacity **61** racks per hour
- Water consumption **0.74** gallons per rack
- Double-wall insulated construction keeps heat inside the machine, reducing energy consumption and heat loss into the dishroom environment
- Variable programmed time cycles - 59, 90 and 210 seconds
- Fully automatic - automatic fill, automatic start, and automatic reset
- Pumped drain for both floor and wall drain applications
- Self cleaning cycle - automatic cleaning of the wash chamber following machine shutdown
- Stainless steel non-clogging wash and rinse arms
- Sloped ceiling is safer for the user and prevents dripping of soiled water onto sanitized ware
- Front mounted controls with digital temperature displays
- 1 Hp wash pump
- All 304 and 316L stainless steel construction for corrosion resistance
- Type A air gap system eliminates need for vacuum breaker
- Easily accessible detergent and rinse aid ports for fast and easy chemical dispenser installation
- Field-convertible for use in either straight-through or corner applications

Options:

- Built-in liquid detergent and rinse aid pumps
- Flanged, bolt-down feet
- External vent fan control with adjustable delay timer
- Drain water tempering kit



Dimensions

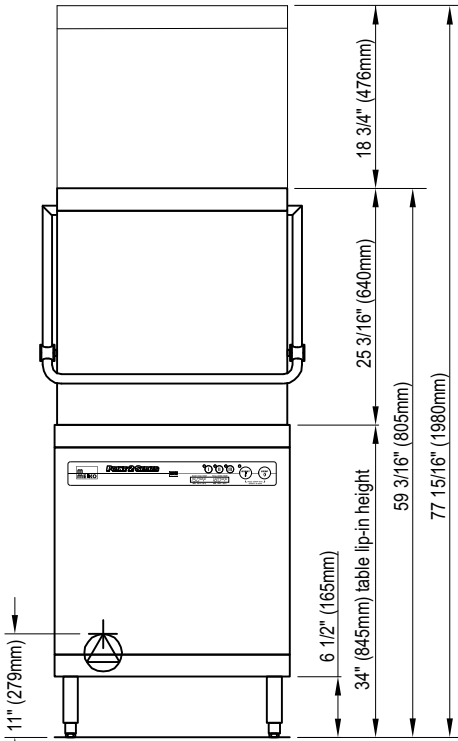

Front Elevation

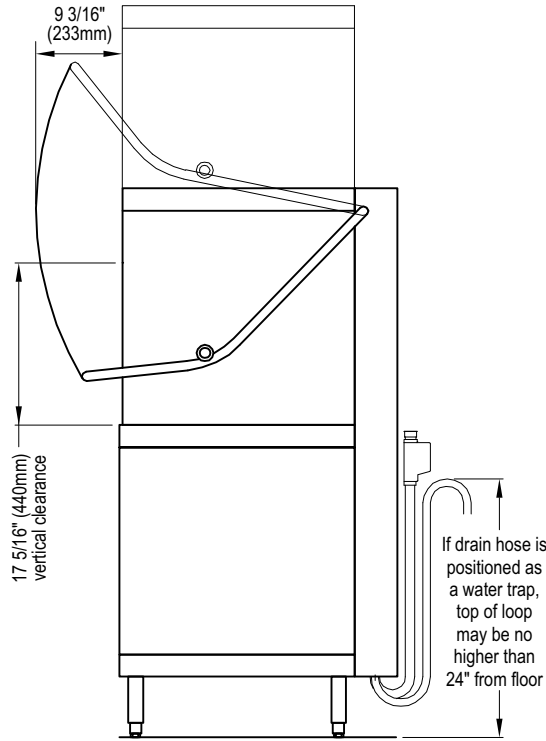

Side Elevation

Legend

-  **E** Electrical terminal block
Strain relief provided at lower rear of machine. Adequate slack in the wiring should be provided to allow the machine to be moved for servicing.
- H** Fresh water connection
3/4" female garden hose supply connection is provided. Removal of supplied adapter provides female 3/4" NPT connection. Either connection may be used as required.
Supplied hose extends 4' 7" from machine connection.
- D** Drain connection
Requires indirect connection to 1-1/2" drain pipe (wall or floor). Supplied hose extends 4' 7" from machine connection.

Plan View

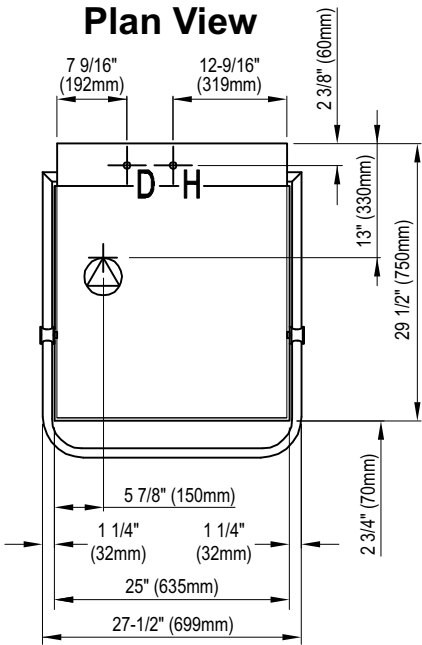

Rack Clearances and Table Positioning

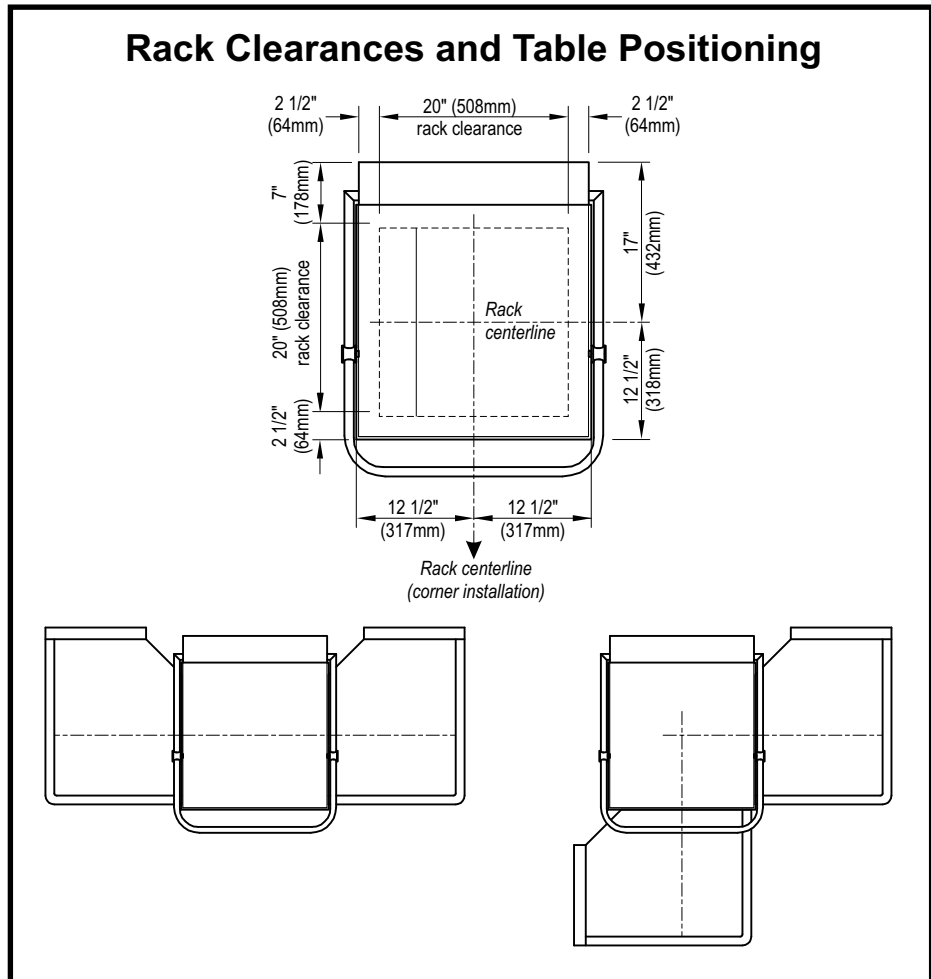

Corner Installations

The DV 80.2 is field-convertible from straight-through to corner application in minutes, without additional parts.

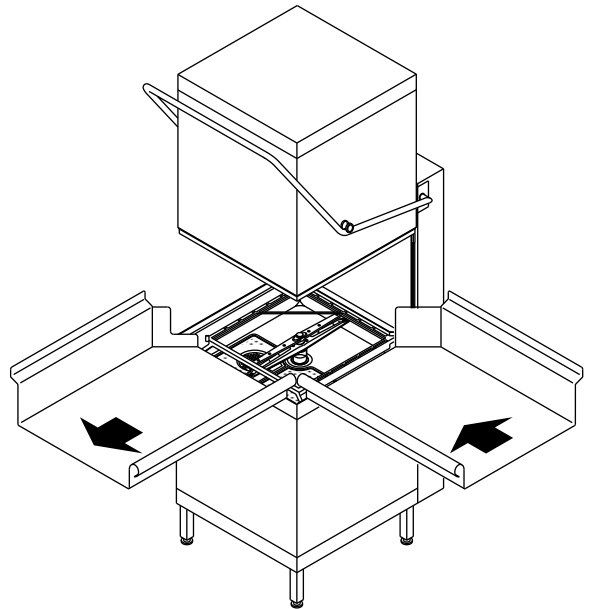
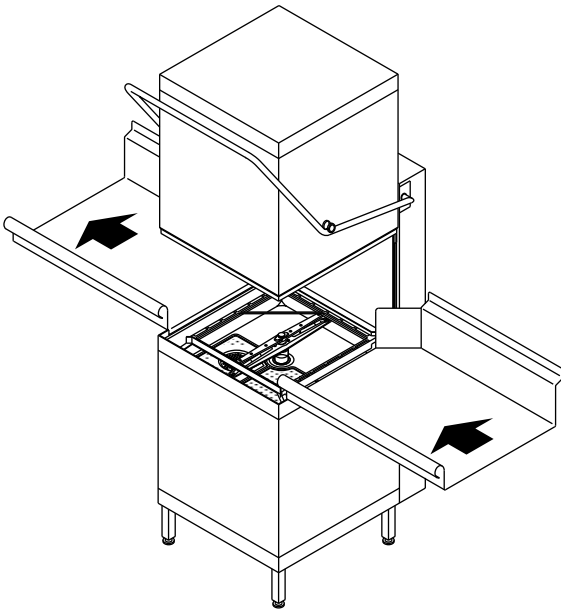

Recommended Tabling Construction

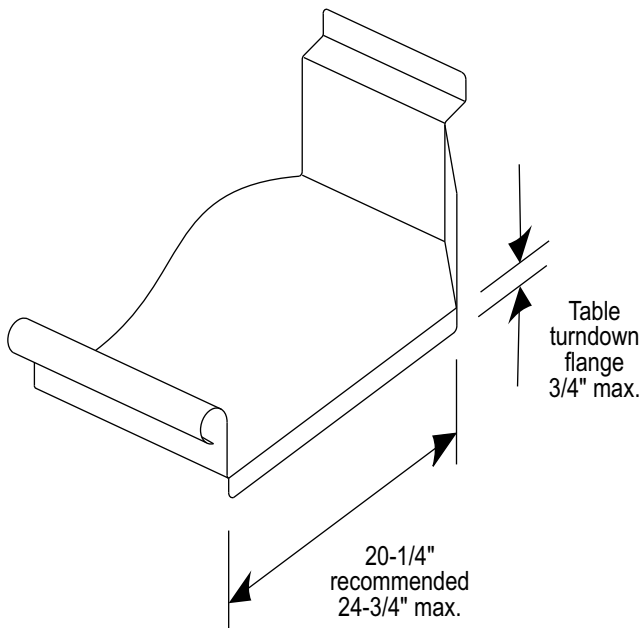

Tabling Cutout for Corner Installations

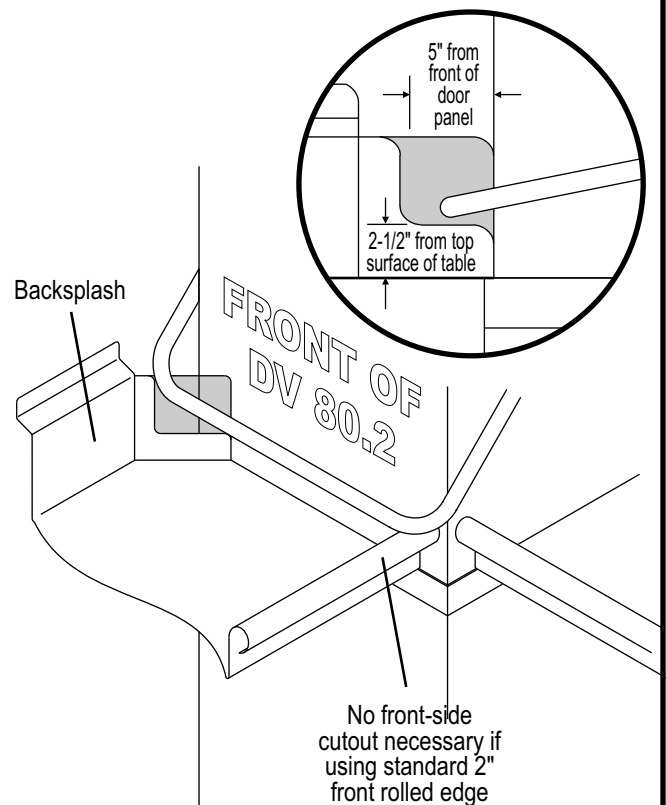

Technical Specifications

Optimum Capacity:

Racks per hour	61
Dishes per hour	1525
Glasses per hour	2196

Optimum Cycle Time (Seconds):

Wash Cycle	40
Dwell / Drain Time	11
Rinse Cycle	8
Total Cycle	59

Water Requirements:

Incoming Water Temperature (Optimum - not required)	140°F
Gallons per Rack	0.74
Gallons per Hour (max)	45.1
Flow Pressure (psi)	8.7-72.5
Incoming Waterline	3/4" male garden hose OR 3/4" male NPT
Drain line Size	3/4" OD flexible hose

Required Operating Temperatures:

Wash (Minimum)	150°F
Rinse (Minimum)	180°F

Tank Capacities:

Wash Tank	5.81 gallons
Booster Heater	2.77 gallons

Electrical Requirements:

Wash Tank Heat	6 kW
Booster Heater	9 kW
Wash Pump	1 HP
Approximate Total Load Amps:	
• 208-230/60/1	64.8 A @ 208V, 71.0 A @ 230V
• 208-230/60/3	50.1 A @ 208V, 54.8 A @ 230V
• 460/60/3	26.7 A @ 460V

Dimensions:

Overall (W x D x H)	25" x 29-7/8" x 58-7/16"
Inside Clearance Height	17-5/16"
Wall Clearance	Rear 1" min.

Machine / Shipping Details:

Machine Weight	254 lbs.
Shipping Weight	296 lbs.
Shipping Size (W x D x H)	29-5/8" x 35-1/2" x 65"

Specification

DV 80.2 Item Number _____

Dishmachine shall be an NSF and UL-approved MEIKO DV 80.2 hot water sanitizing door type dishwasher.

Unit shall be : ___ 208-230 V / 60 Hz / 1 Ph
 ___ 208-230 V / 60Hz / 3 Ph
 ___ 460 V / 60 Hz / 3 Ph

Unit shall have front mounted microcomputer controls, a 59 second total time cycle, and utilize 0.74 gallons fresh rinse water per cycle. Dishmachine shall utilize a fresh water pumped rinse for constant rinse pressure and temperature every cycle. Unit shall have integral wash tank soil removal system to maintain clean wash water and have built-in temperature safeguards to guarantee washing and rinsing at minimum required temperatures. Wash pump shall be equipped with a smooth start feature to eliminate chipped and broken dishware. Unit shall also incorporate features to stop operation and shut off water flow to the machine should leakage occur. Machine shall have variable time cycles for heavier than normal soil loads.

“Auto Safe” Feature

The DV 80.2 guarantees that the minimum NSF 180°F sanitizing final rinse temperature is achieved regardless of the incoming water temperature, even if connected to a cold water line, by automatically extending the wash cycle (if necessary) to provide additional heating time. Listed rack capacity assumes use of recommended 140°F water supply. Exact rack capacity is dependent upon the incoming water temperature and on the electrical supply voltage.

Note: All specifications are subject to change without notice based on MEIKO's dedicated product improvement program.

