



B-US 282 LPW

HOT WATER SANITIZING FLIGHT-TYPE WAREWASHERS

Meiko's flight-type conveyors are the ideal choice for high-volume applications. They feature dramatically improved water savings and Meiko's exclusive Chemical Savings System (CSS) that reduces detergent consumption from 30-50 percent.

Other standard features include computer-positioned wash and prewash arms that are pre-assembled into easily-removed manifolds. Nozzles are slotted and concave to minimize clogging, and feature captivated end caps which can't be lost during cleaning. A double-wall, insulated, flush stainless steel exterior is present on all sides to conserve energy and improve the working environment. Meiko's exclusive, optional Waste Air Heat Recovery System is available on all models. This system eliminates the need for the final hot water rinse to be supplied by an external water heater, and dramatically improves energy efficiency.

As with all products synonymous with the name "Meiko," engineering excellence, manufacturing quality and performance come to the forefront in the B-US 282 LPW flight machine.

Model B-US 282 LPW includes: prewash section, wash section, recirculating rinse section, pumped auxiliary rinse zone, pumped fresh water final rinse.

Standard Features:

- Low NSF-rated water consumption
- High capacity
- Large opening (21-5/8" H x 28-1/2" W) accommodates sheet pans and other large ware
- Pumped auxiliary rinse
- Pumped fresh water final rinse
- Built-in booster heater (steam or electric)
- Standard Chemical Savings System (CSS) Basic reduces detergent consumption by up to 30%
- Flush stainless steel exterior panels with double-wall, insulated construction
- Central control panel with simple electro-mechanical controls
- Start/stop controls at both ends of the machine
- Two-speed conveyor - adjustable during operation to accommodate varying levels of soil
- Stainless steel prewash, wash and recirculating rinse pump assemblies with vertically-mounted, self-draining pumps and powerful 3 hp motors
- V-shaped prewash, wash and recirculating rinse tanks for faster draining and easier cleaning
- Block-manifold wash arms for fast removal and cleaning
- Tethered or "captivated" wash arm end caps
- Slotted, concave, non-clogging wash arm nozzles
- Large, balanced front access doors stay open without latching
- Contacts for external fan control, detergent and rinse aid dispensing systems

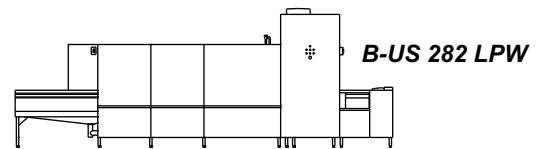

Options:

- **Waste Air Heat Recovery System** - utilizes heat generated by the machine to heat the incoming fresh water. This utilizes "free" energy, eliminates the need for an external boiler or water heater, and allows the machine to use an incoming water supply with temperatures as low as 50°F
- **CSS Top** - additional pre-flushing system prior to the prewash, that includes cyclone separators to actively remove food soil from the recirculated water in the machine. The additional pre-flushing nozzles help to reduce the need for thorough pre-scrapping of ware by the dishroom staff. In addition, reducing the overall soil level of the wash water improves washing performance and reduces detergent consumption by up to 50%
- Steam or electric tank/booster heat
- Single blower dryer (steam or electric)
- Dual blower dryer (steam or electric)
- Low-ceiling configuration (side vent and lower-opening front access doors)
- Split, hinged front access doors
- Load and unload ends in various lengths
- Conveyor belts in varying configurations to accommodate special ware



B-US 282 LPW, Left-to-Right

B-US 282 LPW • Updated 2-07

Front Elevation

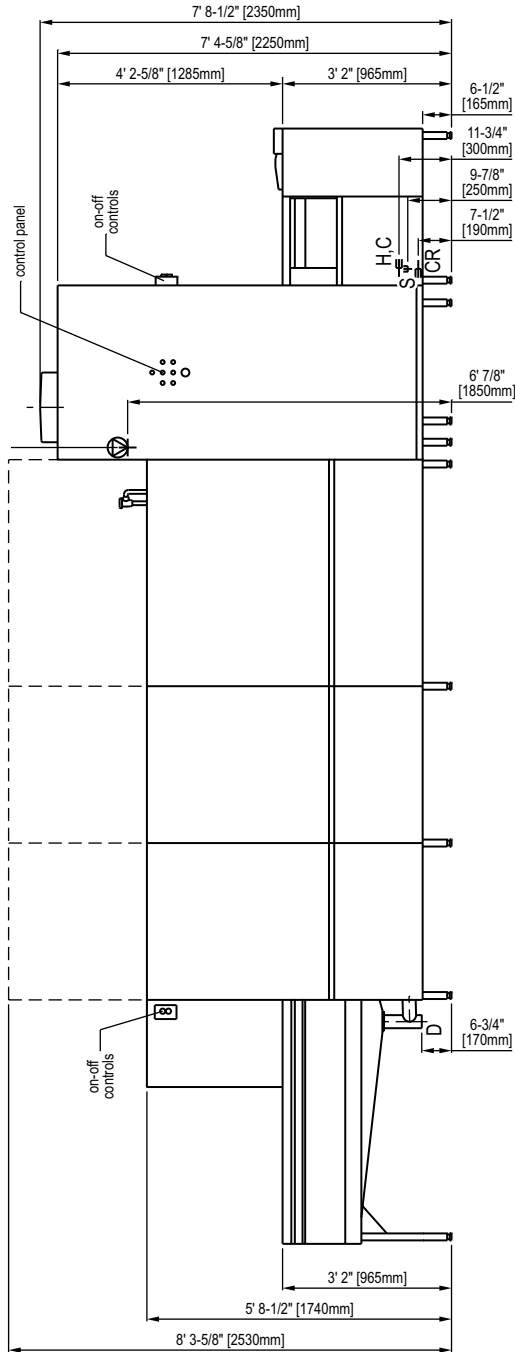

Right Side Elevation

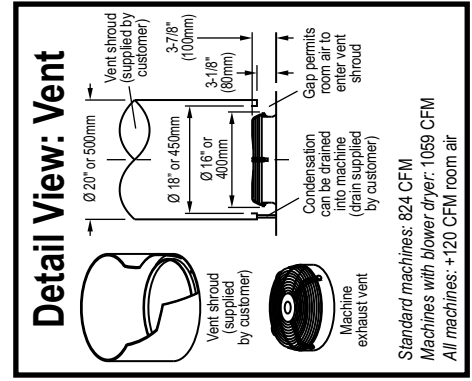
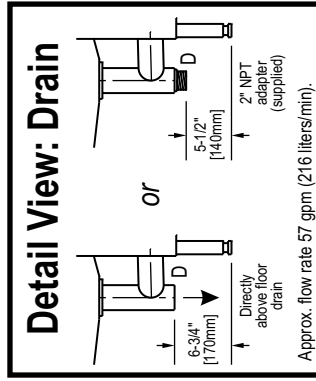
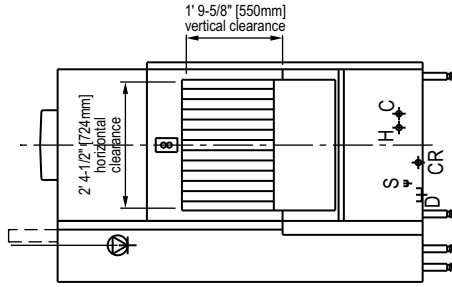

Plan View

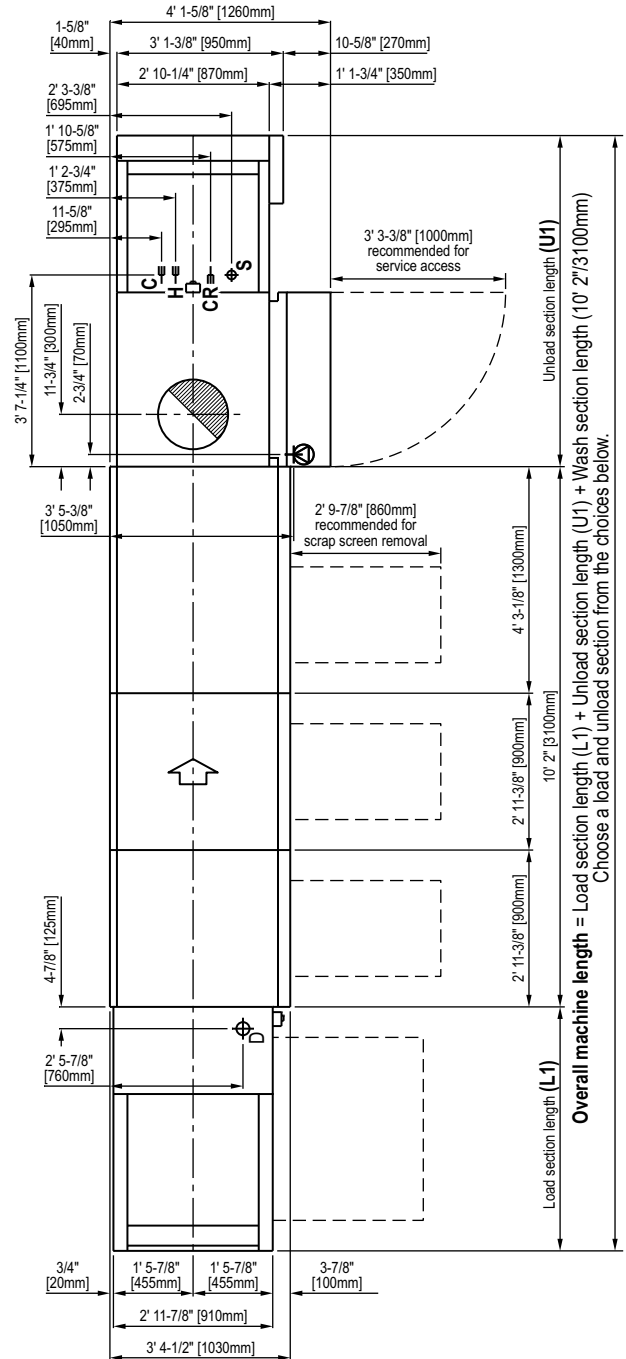

Load Sections - CSS Basic

Load section length (L1)	Clear load area (L2)
3' 7-1/4" (1100mm)	1' 11-5/8" (600mm)
4' 7-1/8" (1400mm)	2' 11-3/8" (900mm)
7' 10-1/2" (2400mm)	6' 2-3/4" (1900mm)
7' 10-1/2" (2400mm) *	6' 2-3/4" (1900mm) *

* With optional 2' 6-3/8" (770mm) loading height

Load Sections - CSS Top

Load section length (L1)	Clear load area (L2)
4' 7-1/8" (1400mm)	1' 11-5/8" (600mm)
5' 6-7/8" (1700mm)	2' 11-3/8" (900mm)
8' 10-3/8" (2700mm) *	6' 2-3/4" (1900mm) *

* With optional 2' 6-3/8" (770mm) loading height

Unload Sections - Standard (no blower dryer)

Unload section length (U1)	Clear unload area (U2)
6' 2-3/4" (1900mm)	2' 11-3/8" (900mm)
8' 6-3/8" (2600mm)	5' 3" (1600mm)
9' 10-1/8" (3000mm)	6' 6-3/4" (2000mm)
10' 9-7/8" (3300mm)	7' 6-1/2" (2300mm)
11' 9-3/4" (3600mm)	8' 6-3/8" (2600mm)
13' 1-1/2" (4000mm)	9' 10-1/8" (3000mm)
16' 7/8" (4900mm)	12' 9-1/2" (3900mm)

Unload Sections - with Blower Dryer

Unload section length (U1)	Clear unload area (U2)
8' 6-3/8" (2600mm)	2' 11-3/8" (900mm)
9' 10-1/8" (3000mm)	4' 3-1/8" (1300mm)
10' 9-7/8" (3300mm)	5' 3" (1600mm)
11' 9-3/4" (3600mm)	6' 2-3/4" (1900mm)
13' 1-1/2" (4000mm)	7' 6-1/2" (2300mm)
16-7/8" (4900mm)	10' 6" (3200mm)

Single blower dryer
 Single blower dryer: 2' 3-1/2" (700mm)
 Dual blower dryer: 5' 5" (1650mm)

Dual blower dryer
 Unload section length (U1) Clear unload area (U2)
 10' 9-7/8" (3300mm) * 2' 1-5/8" (650mm) *
 11' 9-3/4" (3600mm) 3' 1-3/8" (950mm)
 13' 1-1/2" (4000mm) 4' 5-1/8" (1350mm)
 16-7/8" (4900mm) 7' 4-5/8" (2250mm)

* Not recommended for some applications. Consult Meiko before ordering.

Utilities

D Drain
 2-15/16" (75mm) OD vertical, gravity-fed drain outlet (HDPE piping). Optional 2" NPT male adapter supplied.
 4" floor drain recommended. Additional piping to drain (if so required) to be supplied by customer.
 Approx. flow rate 57 gpm (217 liters/min).

Electrical connection
 Machines with electric heat: 4 (four) terminal blocks centered at location shown.
 Machines with steam heat: 1 (one) terminal block at location shown.
 Each terminal block is 4-wire with ground (no neutral). Individual disconnect with lockout/tagout strongly recommended for each supply (provided by customer).
 Opening(s) in the machine for the supply lines are NOT provided and should be executed on-site using appropriate strain relief device(s).

Vent connection
 Indirect connection to machine required to avoid negative pressure inside dishwasher. See **Detail View: Vent**. The connection must be corrosion-resistant and frost-free. In particular, provision must be made to prevent air temperatures of 32°F (0°C) or colder from reaching the machine at any time. A provision for draining moisture from the waste air pipe is **STRONGLY RECOMMENDED**.

H Warm water connection
 Used only for initial fill on units with Waste Air Heat Recovery System.
 Used for both initial fill and final rinse (single water connection) on all other machines.
 3/4" NPT, 110-140°F (43-60°C), 15-25 PSI

C Cold water connection
 Used only for final rinse on units equipped with Waste Air Heat Recovery System. Not present on other units.
 1/2" NPT, 50°F (10°C), 15-25 PSI

Steam Utilities (if so equipped)

S Steam connection
 2" NPT, 15-30 PSI (1-2 bars).
 For steam pressures below 15 PSI (1 bar), contact the factory. For pressures above 30 PSI (2 bars), a regulator is required (supplied by customer).
 CONSTANT steam pressure is REQUIRED. If supply pressure is variable, use of a regulator is REQUIRED (supplied by customer).

CR Condensate return connection
 1-1/4" NPT. Condensate return line MUST be pressure-free.

B-US 282 LPW, Right-to-Left

B-US 282 LPW • Updated 2-07

Right Side Elevation

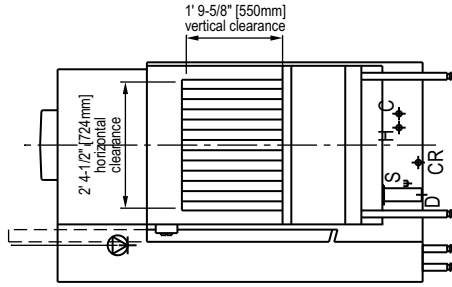

Detail View: Drain

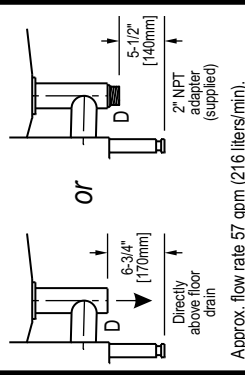

Detail View: Vent

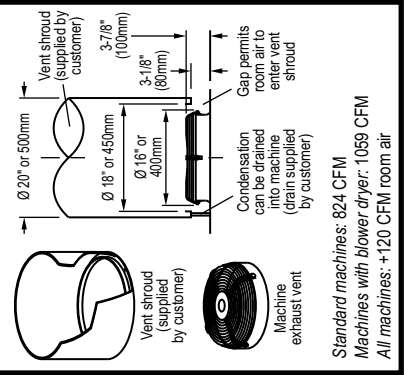

Front Elevation

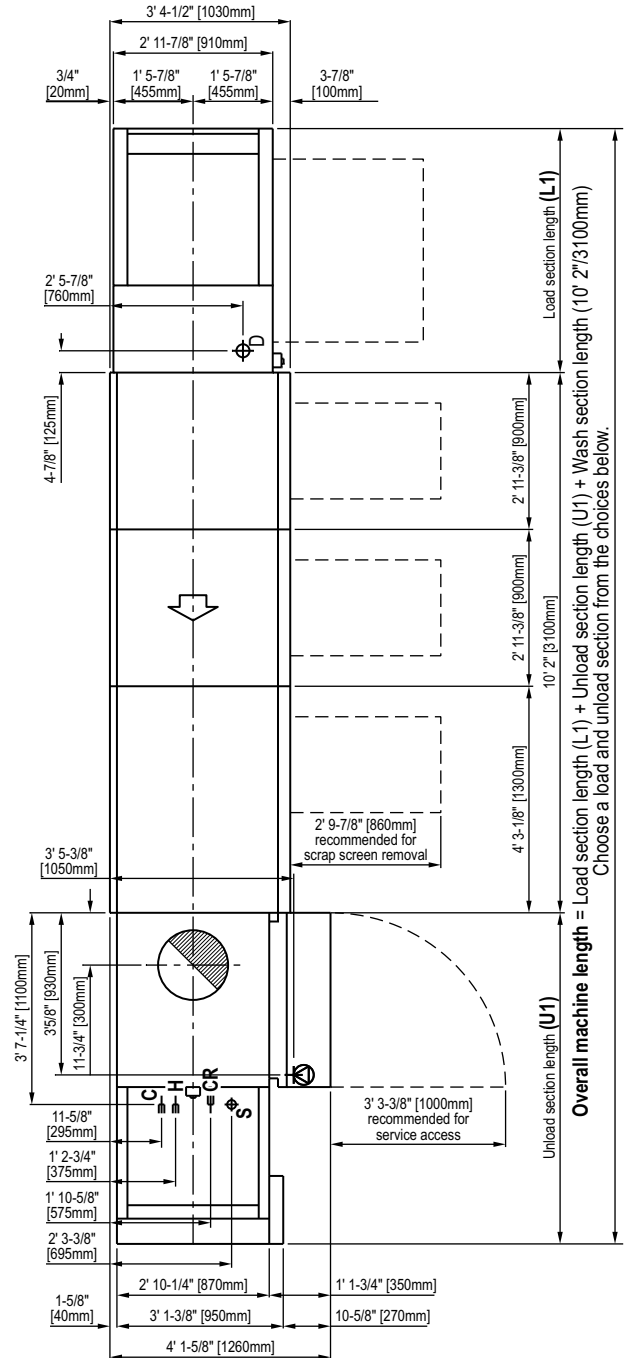
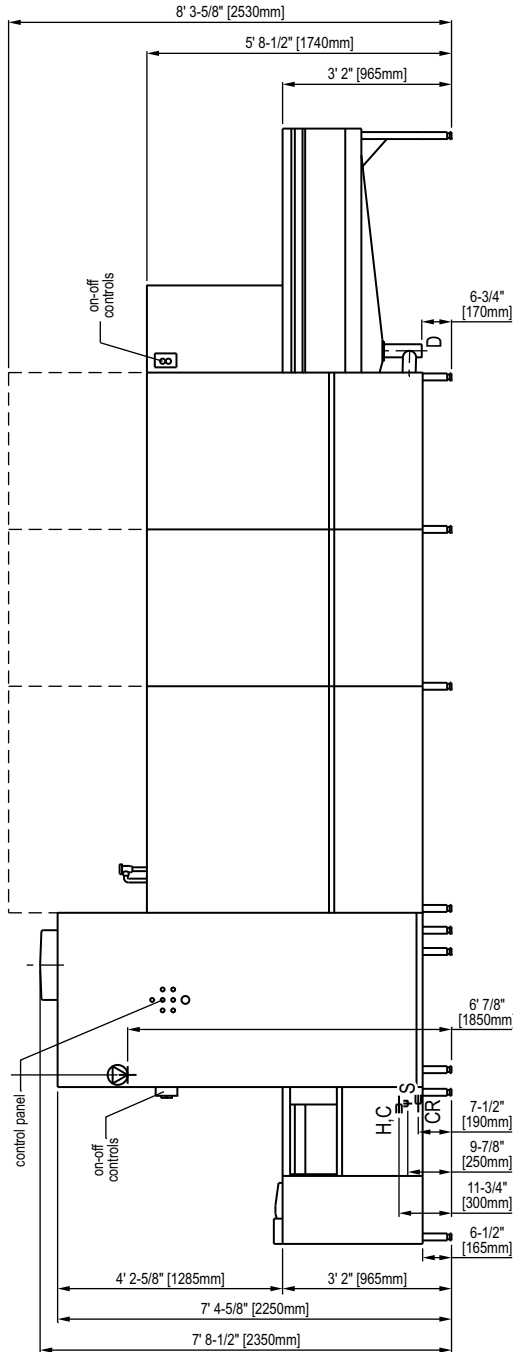

Plan View

Load Sections - CSS Basic

Load section length (L-1)	Clear load area (L2)
3' 7-1/4" (1100mm)	1' 11-5/8" (600mm)
4' 7-1/8" (1400mm)	2' 11-3/8" (900mm)
7' 10-1/2" (2400mm)	6' 2-3/4" (1900mm)
7' 10-1/2" (2400mm) *	6' 2-3/4" (1900mm) *

* With optional 2' 6-3/8" (770mm) loading height

Unload Sections - Standard (no blower dryer)

Unload section length (U1)	Clear unload area (U2)
6' 2-3/4" (1900mm)	2' 11-3/8" (900mm)
8' 6-3/8" (2600mm)	5' 3" (1600mm)
9' 10-1/8" (3000mm)	6' 6-3/4" (2000mm)
10' 9-7/8" (3300mm)	7' 6-1/2" (2300mm)
11' 9-3/4" (3600mm)	8' 6-3/8" (2600mm)
13' 1-1/2" (4000mm)	9' 10-1/8" (3000mm)
16' 7/8" (4900mm)	12' 9-1/2" (3900mm)

Utilities

D Drain
2-15/16" (75mm) OD vertical, gravity-fed drain outlet (HDPE piping). Optional 2" NPT male adapter supplied.
4" floor drain recommended. Additional piping to drain (if so required) to be supplied by customer.
Approx. flow rate 57 gpm (217 liters/min).

Electrical connection
 Machines with electric heat: 4 (four) terminal blocks centered at location shown.
Machines with steam heat: 1 (one) terminal block at location shown. Each terminal block is 4-wire with ground (no neutral). Individual disconnect with lockout/tagout strongly recommended for each supply (provided by customer).
Opening(s) in the machine for the supply lines are NOT provided and should be executed on-site using appropriate strain relief device(s).

Vent connection
 Indirect connection to machine required to avoid negative pressure inside dishwasher. See **Detail View: Vent**. The connection must be corrosion-resistant and frost-free. In particular, provision must be made to prevent air temperatures of 32°F (0°C) or colder from reaching the machine at any time. A provision for draining moisture from the waste air pipe is **STRONGLY RECOMMENDED**.

H Warm water connection
Used only for initial fill on units with Waste Air Heat Recovery System.
Used for both initial fill and final rinse (single water connection) on all other machines.
3/4" NPT, 110-140°F (43-60°C), 15-25 PSI

C Cold water connection
Used only for final rinse on units equipped with Waste Air Heat Recovery System. Not present on other units.
1/2" NPT, 50°F (10°C), 15-25 PSI

Steam Utilities (if so equipped)

S Steam connection
2" NPT, 15-30 PSI (1-2 bars).
For steam pressures below 15 PSI (1 bar), contact the factory. For pressures above 30 PSI (2 bars), a regulator is required (supplied by customer).
CONSTANT steam pressure is REQUIRED. If supply pressure is variable, use of a regulator is REQUIRED (supplied by customer).

CR Condensate return connection
1-1/4" NPT. Condensate return line MUST be pressure-free.

Load Sections - CSS Top

Load section length (L-1)	Clear load area (L2)
4' 7-1/8" (1400mm)	1' 11-5/8" (600mm)
5' 6-7/8" (1700mm)	2' 11-3/8" (900mm)
8' 10-3/8" (2700mm) *	6' 2-3/4" (1900mm) *

* With optional 2' 6-3/8" (770mm) loading height

Unload Sections - with Blower Dryer

Unload section length (U1)	Clear unload area (U2)
8' 6-3/8" (2600mm)	2' 11-3/8" (900mm)
9' 10-1/8" (3000mm)	4' 3-1/8" (1300mm)
10' 9-7/8" (3300mm)	5' 3" (1600mm)
11' 9-3/4" (3600mm)	6' 2-3/4" (1900mm)
13' 1-1/2" (4000mm)	7' 6-1/2" (2300mm)
16-7/8" (4900mm)	10' 6" (3200mm)

Single blower dryer
Unload section length (U1) | Clear unload area (U2)
Single blower dryer: 2' 3-1/2" (700mm)
Dual blower dryer: 5' 5" (1650mm)

Dual blower dryer
Unload section length (U1) | Clear unload area (U2)
10' 9-7/8" (3300mm) * | 2' 1-5/8" (650mm) *
11' 9-3/4" (3600mm) | 3' 1-3/8" (950mm)
13' 1-1/2" (4000mm) | 4' 5-1/8" (1350mm)
16-7/8" (4900mm) | 7' 4-5/8" (2250mm)

* Not recommended for some applications. Consult Meiko before ordering.

Equipment Specification:

B-US 282 LPW Rackless Conveyor Dishwasher - Item No. _____

Item will be a **B-US 282 LPW** flight-type dishmachine. The dishmachine will consist of a prewash compartment with 3 hp pump motor, a wash compartment with 3 hp pump motor, a recirculating rinse compartment with 3 hp pump motor, and a final rinse compartment. Final rinse compartment will consist of a pumped auxiliary rinse and a pumped final rinse, each with a 3/4 hp pump motor. Total length of the tank section will be 10' 2" (3100mm), to which a load and unload end will be added (various sizes are available - see below). Unit will have a maximum capacity of 19,313 dishes per hour at an NSF-rated belt speed of 12 feet (3.7m) per minute, with minimum conveyor peg spacing of 2-1/8" (54mm), while consuming an NSF-rated 159 U.S. gallons (600 liters) per hour.

The dishmachine will be NSF, UL and CUL listed.

Electrical characteristics:

- 208V/60 Hz/3 Ph
 230V/60 Hz/3 Ph
 460V/60 Hz/3 Ph
 Other (specify)

Wash tank temperature will be maintained at a minimum of 160°F/72°C. Tank heating will be accomplished by:

- Thermostatically-controlled electric heating elements
 Thermostatically-controlled stainless steel steam coils

Built-in booster heater (for units without the optional Waste Air Heat Recovery System) will be:

- Electric
 Steam - specify steam pressure: _____ PSI.

NOTE: 15-30 PSI (1.0-2.0 bars) steam pressure is REQUIRED. Consult the factory if pressure is below 15 PSI/1.0 bars. If pressure is above 30 PSI/2.0 bars, use of a regulator (supplied by the customer) is REQUIRED.

- Sized for a minimum 40°F (22°C) rise and 140°F (60°C) minimum incoming water temperature
 Sized for a minimum 70°F (39°C) rise and 110°F (43°C) minimum incoming water temperature

Direction of conveyor travel will be:

- Right-to-Left
 Left-to-Right

Unit will have the following size load end (for units without the optional CSS Top system):

- 3' 7-1/4" (1100mm) with 1' 11-5/8" (600mm) clear loading area and 3' 2" (965mm) loading height
 4' 7-1/8" (1400mm) with 2' 11-3/8" (900mm) clear loading area and 3' 2" (965mm) loading height
 7' 10-1/2" (2400mm) with 6' 2-3/4" (1900mm) clear loading area and 3' 2" (965mm) loading height
 7' 10-1/2" (2400mm) with 6' 2-3/4" (1900mm) clear loading area and 2' 9" (830mm) loading height

Unit will have the following size unload end (for units without an optional blower dryer system):

- 6' 2-3/4" (1900mm) with 2' 11-3/8" (900mm) clear unloading area
 8' 6-3/8" (2600mm) with 5' 3" (1600mm) clear unloading area
 9' 10-1/8" (3000mm) with 6' 6-3/4" (2000mm) clear unloading area
 10' 9-7/8" (3300mm) with 7' 6-1/2" (2300mm) clear unloading area
 11' 9-3/4" (3600mm) with 8' 6-3/8" (2600mm) clear unloading area
 13' 1-1/2" (4000mm) with 9' 10-1/8" (3000mm) clear unloading area
 16' 7/8" (4900mm) with 12' 9-1/2" (3900mm) clear unloading area

Unit will have the following standard features:

- High temperature sanitizing final rinse.
- Pumped final rinse and auxiliary rinse to eliminate pressure fluctuations, improve machine performance, and improve cleaning results and consistency.
- Heated auxiliary rinse zone utilizes fresh water a second time as a pre-rinse to provide pristine results.
- Horizontal clearance of 2' 4-1/2" (725mm) and a vertical clearance of 1' 9-5/8" (550mm) throughout the machine.
- Double-wall insulated construction to reduce heat loss, outside surface temperatures, and noise pollution.
- Flush stainless steel exterior panels on front, top and back.
- Front-sloping, V-shaped wash tank design to increase visibility and accessibility for cleaning as well as ensure complete tank draining.
- CSS Basic (Chemical Savings System) reduces detergent consumption by up to 30% by diverting used rinse water into the prewash section, reducing food debris contamination in the wash tank.
- Vertically-installed self-draining stainless steel pumps, impellers and housings are readily accessible for preventative maintenance.

- Easily-removable block manifold wash arms with tethered (or “captivated”) end caps and non-clogging concave nozzles to aid cleanability.
- Large, easily-removable, front-sloping stainless steel scrap screens. Prewash scrap screen has a separate removable scrap basket for easier cleaning.
- Dual-speed conveyor drive for flexibility. Drive is protected by an overload safety device and automatic shutdown actuator.
- Large, insulated front access doors have counterbalanced springs to permit single-handed operation and to eliminate latches.
- Operator-activated start-stop switches on both load and unload ends.
- Automated timer switching ensures that the final rinse activates only when ware is in place.
- Single-point drain and vent connections.
- Potential free contacts for controlling 1 or 2 external fan contactors.
- Potential free contacts for controlling external detergent and rinse aid dispensing systems.
- Potential free contacts for controlling a contactor for an external transport delivery system.

Unit will have these optional features:

_____ Meiko’s exclusive “Waste Air Heat Recovery System” which utilizes the heat generated by (and normally exhausted from) the machine as free energy to preheat the incoming rinse water. In addition to saving energy, this feature allows the use of incoming rinse water with temperatures as low as 50°F (10°C).

_____ Meiko’s exclusive CSS Top (Chemical Savings System) - a dedicated pre-flushing system located prior to the prewash that receives cooled water directly from the auxiliary rinse zone. CSS Top flushes food debris directly from the ware and removes food soil by filtering the water through two cyclone separators. This reduces wash water contamination, reducing detergent consumption by up to 50%. Requires the machine to be equipped with the Waste Air Heat Recovery System.

Unit will have the following size load end with CSS Top option:

_____ 4’ 7-1/8” (1400mm) with 1’ 11-5/8” (600mm) clear loading area and 3’ 2” (965mm) loading height

_____ 5’ 6-7/8” (1700mm) with 2’ 11-3/8” (900mm) clear loading area and 3’ 2” (965mm) loading height

_____ 8’ 10-3/8” (2700mm) with 6’ 2-3/4” (1900mm) clear loading area and 2’ 9” (830mm) loading height

_____ A built-in single blower dryer for complete drying of all dishes, crockery and silverware.

Blower dryer will be:

_____ Steam-heated

_____ Electrically heated

Length of unload end will be:

_____ 8’ 6-3/8” (2600mm) with 2’ 11-3/8” (900mm) clear unloading area

_____ 9’ 10-1/8” (3000mm) with 4’ 3-1/8” (1300mm) clear unloading area

_____ 10’ 9-7/8” (3300mm) with 5’ 3” (1600mm) clear unloading area

_____ 11’ 9-3/4” (3600mm) with 6’ 2-3/4” (1900mm) clear unloading area

_____ 13’ 1-1/2” (4000mm) with 7’ 6-1/2” (2300mm) clear unloading area

_____ 16’ 7/8” (4900mm) with 10’ 6” (3200mm) clear unloading area

_____ Built-in dual blower dryers, for complete drying of all plastics and trays, as well as all dishes, crockery and silverware.

Blower dryer will be:

_____ Steam-heated

_____ Electrically heated

Length of unload end will be:

_____ 10’ 9-7/8” (3300mm) with 2’ 1-5/8” (650mm) clear unloading area

_____ 11’ 9-3/4” (3600mm) with 3’ 1-3/8” (950mm) clear unloading area

_____ 13’ 1-1/2” (4000mm) with 4’ 5-1/8” (1350mm) clear unloading area

_____ 16’ 7/8” (4900mm) with 7’ 4-5/8” (2250mm) clear unloading area

_____ A factory-installed external fan control option as described below:

_____ One contactor for controlling an external fan. Replaces one set of potential free contacts (see Standard Features). Maximum 600VAC, 35A, 3 Ph.

_____ Two contactors for controlling external fan(s). Replaces both sets of potential free contacts (see Standard Features). Maximum 600VAC, 35A, 3 Ph.

Note: Consult the factory for more options, systems and accessories. Some available items include:

- Low ceiling height option, including side ventilation fan and lower-opening front access doors
- Hinged, split front access doors
- Special conveyor belt and peg configurations for a variety of ware and flexibility
- Conveyor belts for special ware requirements - larger or heavier ware, specialized cutlery track, etc.
- Lateral wash arm systems for machines primarily intended to wash partitioned, compartmentalized, or insulated trays
- Complete customized systems consisting of soiled and clean ware conveyors to transport trays and loose ware to and from the dishmachine
- Automatic accumulators and stackers

B-US 282 LPW Technical Specifications

Operating Capacities

Dishes per hour (max.)	19,313
Consumption (per hour)	159 gals(600 liters)

Conveyor Specifications

Conveyor belt speed	
Minimum	8'(2.4m)/min
Maximum	12'(3.7m)/min
Horizontal clearance	2'4-1/2"(725mm)
Vertical clearance	1'9-5/8"(550mm)
Minimum peg spacing	2-1/8" (55mm)

Water Specifications

Minimum water temperatures:

Prewash tank	110°F (43°C)
Wash tank	150°F (66°C)
Recirculating rinse tank	160°F (72°C)
Auxiliary rinse tank	165°F (72°C)
Final rinse	180°F (82°C)

Water requirements:

Minimum incoming temp. - machines with single water connection	
40°F/22°C rise	140°F (60°C)
70°F/39°F rise	110°F (43°C)

Minimum incoming temp. - machines with WAHRS option

Fill line	110°F (43°C)
Final rinse line	50°F (10°C)

Venting requirements

Volume (standard)	942 CFM (26.4m³/min.)
Volume (with blower dryer)	1177 CFM (33.0m³/min.)
Room air	+ 120 CFM (3.4m³/min.)
Air temp. (approx.)	122°F (50°C)
Air temp. (approx.) w/Waste Air Heat Recovery System	95°F (35°C)

Drain requirements

Connection (standard)	3" (75mm) OD
Connection (with supplied adapter)	2" NPT
Flow rate (typical)	57 GPM (216 liters/min.)

Initial fill	127 gals(480 liters)
Consumption (per hour)	159 gals(600 liters)
Final rinse flow rate per minute	2.7 gals(10.0 liters)
Incoming water line - machines with single water connection	
Fill/rinse line	3/4" NPT
Incoming water line - machines with WAHRS option	
Fill line	3/4" NPT
Final rinse line	1/2" NPT
Recommended water pressure	15-25 PSI (1.0-1.7 bars)
Recommended water hardness	1-6 grains/gal.

Machine Electrical Specifications

	208 V/60 Hz/3 Ph				230 V/60 Hz/3 Ph				460 V/60 Hz/3 Ph			
	TB1	TB2	TB3	TB4	TB1	TB2	TB3	TB4	TB1	TB2	TB3	TB4
Electric tank heat with 40°F booster	38.8A	108.4A	50.0A	50.0A	38.7A	109.2A	51.0A	43.6A	16.5A	48.8A	22.6A	22.6A
Electric tank heat with 70°F booster	38.8A	108.4A	50.0A	83.4A	38.7A	109.2A	51.0A	72.8A	16.5A	48.8A	22.6A	37.6A
Electric tank heat with WAHRS option	38.8A	108.4A	50.0A	83.4A	38.7A	109.2A	51.0A	72.8A	16.5A	48.8A	22.6A	37.6A
Steam tank heat with steam booster	38.8A	--	--	--	38.7A	--	--	--	16.5A	--	--	--
CSS Top option	+3.9A	--	--	--	+3.9A	--	--	--	+2.3A	--	--	--
Single blower dryer, machines with electric heat	+1.6A	--	+24.9A	--	+1.4A	--	+21.9A	--	+0.8A	--	+11.4A	--
Dual blower dryer, machines with electric heat	+3.1A	--	+24.9A	--	+2.7A	--	+21.9A	--	+1.6A	--	+11.4A	--
Single blower dryer, machines with steam heat	+1.6A	--	--	--	+1.4A	--	--	--	+0.8A	--	--	--
Dual blower dryer, machines with steam heat	+3.1A	--	--	--	+2.7A	--	--	--	+1.6A	--	--	--

Component Electrical Specifications

Prewash pump motor	3.0 hp (2.2 kW)	Electric Heating Elements (electrically-heated units only)		
Wash pump motor	3.0 hp (2.2 kW)		208 V/60 Hz/3 Ph	208 V/60 Hz/3 Ph
Recirculating rinse pump motor	3.0 hp (2.2 kW)	Wash tank	12.0 kW	14.5 kW
Auxiliary rinse pump motor	0.75 hp (0.55 kW)	Recirculating rinse tank	27.0 kW	29.0 kW
Final rinse pump motor	0.75 hp (0.55 kW)	Auxiliary rinse tank	18.0 kW	20.3 kW
Conveyor motor	0.17/0.25 hp (0.07-0.19 kW)	Booster heater / 40°F rise	18.0 kW	17.4 kW
Vent motor	0.45 hp (0.34 kW)	Booster heater / 70°F rise	30.0 kW	29.0 kW
CSS Top pump motor	1.0 hp (0.75 kW)	Booster heater / Waste air heat recovery option, 130°F rise	30.0 kW	29.0 kW
Blower dryer motor, 208V or 230V	0.45 hp (0.34 kW)	Blower dryer heater (single or dual blower dryers)	1 x 9.0 kW	1 x 8.7 kW
Blower dryer motor, 460V	0.58 hp (0.43 kW)			1 x 9.0 kW

Steam Specifications (steam-heated units only)

Steam line connection	2" NPT	Consumption	40°F/22°C rise	70°F/49°C rise	WAHRS option
Condensate return connection	1-1/4" NPT	Tank heat and booster heat	275 lbs./hr. (81 kW)	319 lbs./hr. (93 kW)	319 lbs./hr. (93 kW)
Steam pressure	15-30 psi (1-2 bars)	Blower dryer	+33 lbs./hr. (9 kW)	+33 lbs./hr. (9 kW)	+33 lbs./hr. (9 kW)

Note: All specifications are subject to change without notice based on Meiko's dedicated product improvement program.